

Commercial Direct Gear Drive Bin Sweep Auger

Assembly & Operation Manual

PNEG-1521

Date: 10-25-2007

GSI GROUP



PNEG-1521

This manual is valid for the sweep catalog numbers in the table below.

Bin Dia.	10" Commercial DGD Sweep
36'	CPS10360
42'	CPS10420
48'	CPS10480
54'	CPS10540
60'	CPS10600
72'	CPS10720
75'	CPS10750
78'	CPS10780

TABLE OF CONTENTS

Introduction	4
Safety Guidelines	5
Safety Instructions	6-8
Operator Qualifications	9
Decals	10-11
Installation Section	
Power Sweeps in Bins with Concrete Floors	12
Power Sweeps in Bins with Raised Metal Floors	13
Intermediate Well Installation	14
Unload Tube Assembly Installation	15-16
Outer Unload Tube Assembly Installation	17-18
Centerwell Control Gate Assembly	19
Bin Flange Installation	20
Rack & Pinion Installation	21-22
Clutch Control Installation	23-24
Assembling and Installing the Unload Flight	25-26
Installing the Sweep Flighting	27-31
Sweep Wheel Installation	32-34
Motor Selection	35
Before Filling the Bin	36
Pre-Start Checks	37
Normal Operation	38-39
Engaging the Clutch for the Bin Sweep	40
Final Clean-Out	41-42
Shutdown	43
Maintaining the Auger	44
Troubleshooting	45-46
Parts Section	
Parts	47-62
Warranty	63

INTRODUCTION

READ THIS MANUAL carefully to learn how to properly use and install equipment. Failure to do so could result in personal injury or equipment damage.

INSPECT the shipment immediately upon arrival. The Customer is responsible for ensuring that all quantities are correct. Report any damage or shortages by recording a detailed description on the Bill of Lading to justify the Customer's claim from the Transport Firm.

THIS MANUAL SHOULD BE CONSIDERED a permanent part of your equipment and should be easily accessible when needed.

WARRANTY is provided as part of the company's support program for customers who use and maintain their equipment as described in the manual. The warranty is explained on the warranty page located on the inside of the back cover.

This warranty provides you the assurance that the company will back its products where defects appear within the warranty period. Should the equipment be abused, or modified to change its performance beyond the factory specifications, the warranty will become void.

SAFETY GUIDELINES

This manual contains information that is important for you, the owner/operator, to know and understand. This information relates to protecting **personal safety** and **preventing equipment problems**. It is the responsibility of the owner/operator to inform anyone operating or working in the area of this equipment of these safety guidelines. To help you recognize this information, we use the symbols that are defined below. Please read the manual and pay attention to these sections. Failure to read this manual and it's safety instructions is a misuse of the equipment and may lead to serious injury or death.



This is the safety alert symbol. It is used to alert you to potential personal injury hazards. Obey all safety messages that follow this symbol to avoid possible injury or death.



DANGER indicates an imminently hazardous situation which, if not avoided, will result in death or serious injury.



WARNING indicates a potentially hazardous situation which, if not avoided, could result in death or serious injury.



CAUTION indicates a potentially hazardous situation which, if not avoided, may result in minor or moderate injury.



CAUTION used without the safety alert symbol indicates a potentially hazardous situation which, if not avoided, may result in property damage.



NOTE indicates information about the equipment that you should pay special attention to.

SAFETY INSTRUCTIONS

GSI's principle concern is your safety and the safety of others associated with grain handling equipment. We want to keep you as a customer. This manual is to help you to understand safe operating procedures and some problems which may be encountered by the operator and other personnel.

As owner and/or operator, it is your responsibility to know what requirements, hazards and precautions exist, and to inform all personnel associated with the equipment or in the area. Safety precautions may be required from the personnel. Avoid any alterations to the equipment. Such alterations may produce a very dangerous situation, where **SERIOUS INJURY** or **DEATH** may occur.

This equipment shall be installed in accordance with the current installation codes and applicable regulations which should be carefully followed in all cases. Authorities having jurisdiction should be consulted before installations are made.

OPERATE UNLOAD EQUIPMENT PROPERLY

Make sure ALL equipment is locked in position before operating.

NEVER start equipment until ALL persons are clear of the work area.

Be sure all operators are adequately rested and prepared to perform all functions of operating this equipment.

NEVER allow any person intoxicated or under the influence of alcohol or drugs to operate the equipment.

NEVER work alone.

Make sure someone is nearby who is aware of the proper shutdown sequence in the event of an accident or emergency.

ALWAYS think before acting. **NEVER** act impulsively around the equipment.

NEVER allow anyone inside a bin, truck or wagon which is being unloaded by an auger or conveyor. Flowing grain can trap and suffocate in seconds.

Use ample overhead lighting after sunset to light the work area.

Keep area around intake free of obstacles such as electrical cords, blocks, etc., that might trip workers.

NEVER drive, stand or walk under the equipment.

Use caution not to hit the auger when positioning the load.

ALWAYS lockout ALL power to the equipment when finished unloading a bin.



**Operate
Unload
Equipment
Safely**

FOLLOW SAFETY INSTRUCTIONS

Carefully read all safety messages in this manual and on your machine safety signs. Keep signs in good condition. Replace missing or damaged safety signs. Be sure new equipment components and repair parts include the current safety signs. Replacement safety signs are available from the manufacturer.

Learn how to operate the machine and how to use controls properly. Do not let anyone operate without instruction.

Keep your machinery in proper working condition. Unauthorized modifications to the machine may impair the function and/or safety and affect machine life.

If you do not understand any part of this manual and need assistance, contact your dealer.

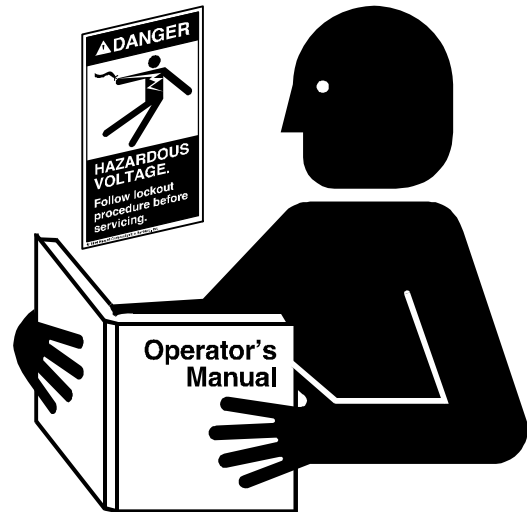

Read and Understand Manual.

INSTALL & OPERATE ELECTRICAL EQUIPMENT PROPERLY

To avoid serious injury or death, stay away from unit and make sure everyone is clear of all augers before starting or operating the unit.

Electrical controls should be installed by a qualified electrician and must meet the standards set by the national electrical code and all local and state codes.

Disconnect and lock out all power sources before installing wires/cables or servicing equipment .

Do not operate electric motor equipped units until motors are properly grounded.

Disconnect power on electrical driven units before resetting motor overloads.

Do not repetitively stop and start the drive in order to free a plugged condition. Jogging the drive in this type of condition can damage the equipment.



Electric Shock Hazard.

SAFETY

PREPARE FOR EMERGENCIES

Be prepared if fire starts.

Keep a first aid kit and fire extinguisher handy.

Keep emergency numbers for doctors, ambulance service, hospital, and fire department near your telephone.

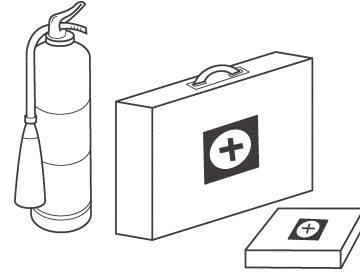

Keep Emergency Equipment Quickly Accessible.

WEAR PROTECTIVE CLOTHING

Wear close fitting clothing and safety equipment appropriate to the job.

Safety glasses should be worn at all times to protect eyes from debris.

Wear gloves to protect your hands from sharp edges on plastic or steel parts.

A respirator may be needed if a hog house has poor ventilation. Waste fumes can be toxic.

Wear hard hat and steel toe boots to help protect your head and toes from falling debris.

Remove all jewelry.

Tuck in any loose or dangling shoe strings.

Long hair should be tied up and back.

Eye Protection

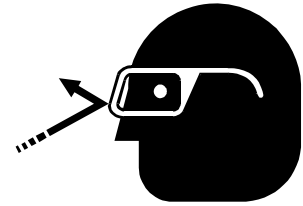

Gloves



Steel Toe Boots



Respirator

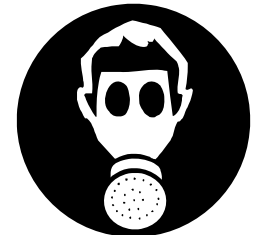

Hard Hat



OPERATOR QUALIFICATIONS.

- A. The User/Operator must be competent and experienced to operate auger equipment. Anyone who works with or around augers must have good common sense in order to be qualified. These persons must also know and meet all other qualifications, such as:
1. Any person who has not read and/or does not understand all operation and safety instructions is not qualified to operate any auger systems.
 2. Certain regulations apply to personnel operating power machinery. Personnel under the age of 18 years may not operate power machinery, including augers. It is your responsibility, as owner and/or supervisor, to know what these regulations are in your area or situation.
 3. Unqualified or incompetent persons are to remain out of work area.
 4. O.S.H.A. (Occupational Safety & Health Administration) regulations state: "At the time of initial assignment and at least annually thereafter, the employer shall instruct every employee in the safe operation and servicing of all equipment with which the employee is, or will be involved". (Federal Occupational Safety & Health Standards for Agriculture. Sub part D, Section 19287.57 (a) (6).
- B. As a requirement of OSHA, it is necessary for the employer to train the employee in the safe operating and safety procedures for this auger. We included this sign-off sheet for your convenience and personal record keeping. All unqualified people are to stay out of the work area at all times. It is strongly recommended that another qualified person who knows the shutdown procedure is in the area in the event of an emergency. A person who has not read this manual and understands all operating and safety instructions, is not qualified to operate the machine.

<i>Date</i>	<i>Employees Name (printed)</i>	<i>Employees Signature</i>
	1	
	2	
	3	
	4	
	5	
	6	
	7	
	8	
	9	
	10	
	11	
	12	
	13	
	14	
	15	

SAFETY DECALS

Check the components shown below to insure that the safety decals are in place and in good condition. If a decal cannot be easily read for any reason or has been painted over, replace it immediately. Contact your dealer or the manufacturer to order a replacement decal free of charge.

DECAL PART LIST		
Part #	Description	Size
DC-1266	Danger - Bin Well	7-1/2" x 2-1/2"
DC-1384	Danger - Keep Out Of Bin	6-1/4" x 1-3/4"
DC-1866	Important - Power Sweep Information (≥ 42' Bin)	7-3/8" x 2-3/4"
DC-1834	Important - Power Sweep Information (36' Bin)	7-3/8" x 2-3/4"
DC-1395	Danger - Rotating Flight	4-1/4" x 6-1/4"

IMPORTANT: BEFORE FILLING BIN CLOSE CENTER WELL AND INTERMEDIATE WELL GATES. POSITION SWEEP AUGER OVER INTERMEDIATE WELLS.

INSTRUCTIONS:

1. BE SURE POWER SWEEP CLUTCH CONTROL IS DISENGAGED AND TIGHTEN SET SCREW.
2. START UNLOADING AUGER. OPEN CENTER WELL GATE.
3. WHEN GRAIN STOPS FLOWING FROM CENTER WELL GATE, OPEN INSIDE INTERMEDIATE WELLS BEFORE OPENING OUTSIDE INTERMEDIATE WELLS.
4. WHEN GRAIN STOPS FLOWING FROM OUTSIDE INTERMEDIATE WELLS, STOP AUGER. TO ENGAGE POWER SWEEP, ROTATE UNLOADING AUGER SLOWLY UNTIL CLUTCH ENGAGES AND TIGHTEN SET SCREW. START AUGER.

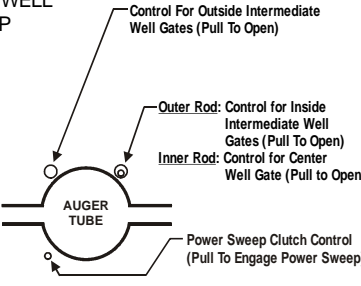

Control For Outside Intermediate Well Gates (Pull To Open)

Outer Rod: Control for Inside Intermediate Well Gates (Pull To Open)

Inner Rod: Control for Center Well Gate (Pull to Open)

AUGER TUBE

Power Sweep Clutch Control (Pull To Engage Power Sweep)

DC-1866

DC-1866

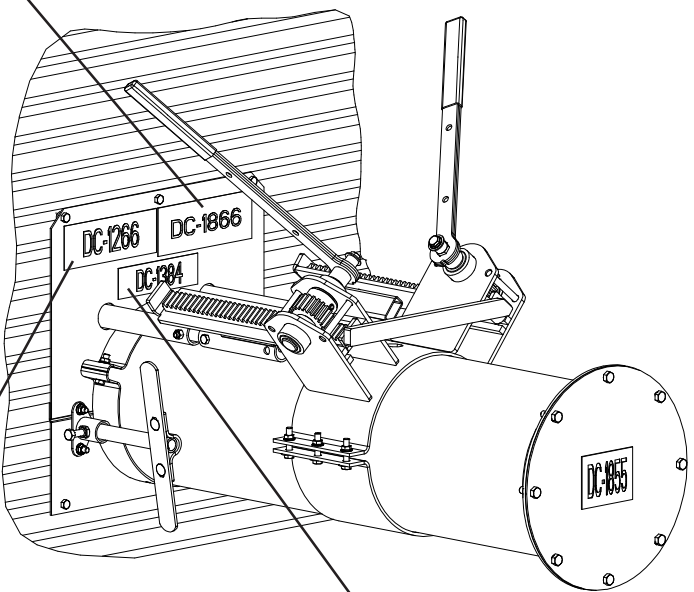

⚠ DANGER

- KEEP OUT OF BIN DURING UNLOADING OPERATIONS.
- WHEN BIN WELLS ARE IN OPEN POSITION CONVEYING MECHANISM IS NOT COVERED.

FAILURE TO HEED WILL RESULT IN SERIOUS INJURY OR DEATH!

DC-1266

DC-1266

⚠ DANGER

KEEP OUT OF BIN WHILE SWEEP IS IN OPERATION RAPIDLY TRAVELING SWEEP AUGER

FAILURE TO HEED WILL RESULT IN SERIOUS INJURY OR DEATH

DC-1384

DC-1384

SAFETY DECALS

DANGER Decal No. DC-1395 was supplied with your Bin Unloading equipment. This safety sign should be applied to the side of the bin near the bin opening, so it will be viewed by people entering into the bin storage building. Do not cover any safety signs or any other signs that are already present.

NOTE

Please remember, safety signs provide important safety information for people working near bin unloading equipment that is in operation.



DC-1384

Located on the back of the Flight Shield.

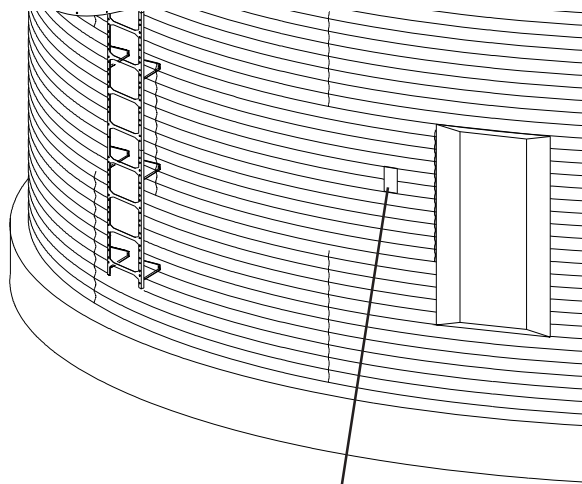
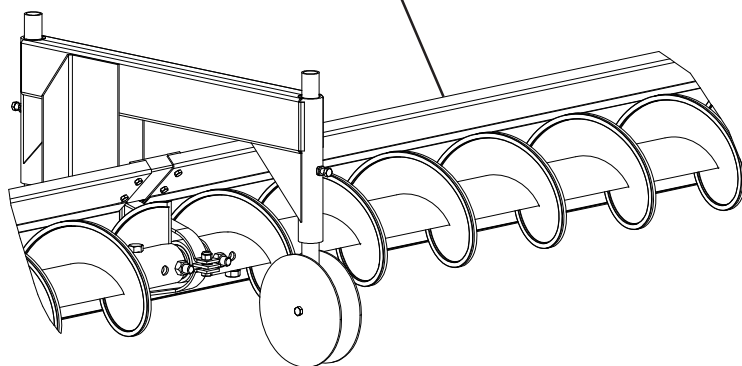

DC-1395

WARNING

If the Safety Sign cannot be easily read for any reason or has been painted over, replace it immediately. Additional Safety Signs may be obtained *free of charge* from your dealer, distributor, or ordered from the factory.

1. POWER SWEEPS IN BINS WITH CONCRETE FLOORS

NOTE The company does not recommend setting the Direct Gear Drive Bin Sweep unit in concrete. If installing a unit flush with a concrete floor, we recommend the unit be installed in a preformed trench. Use the diagram below.

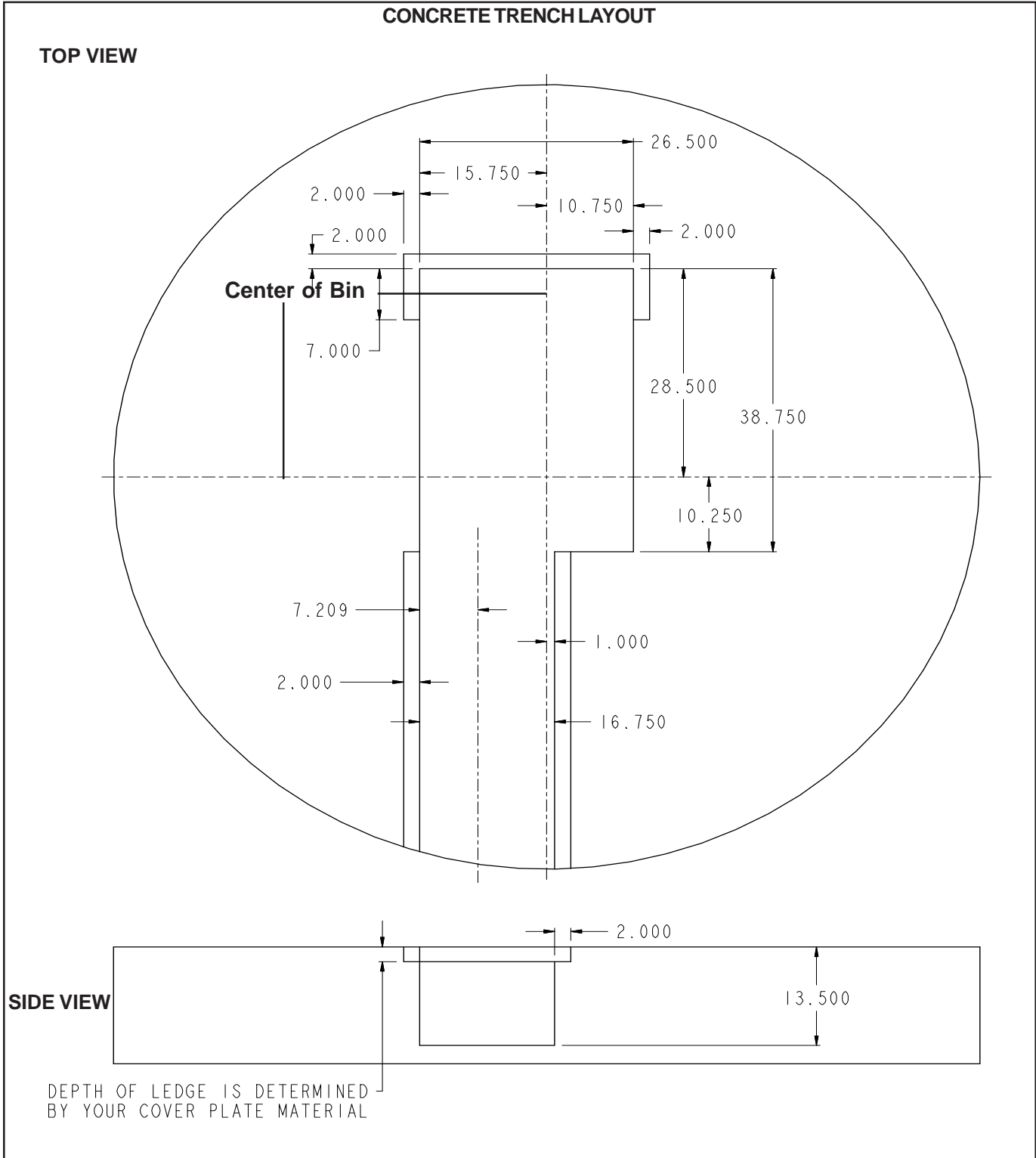
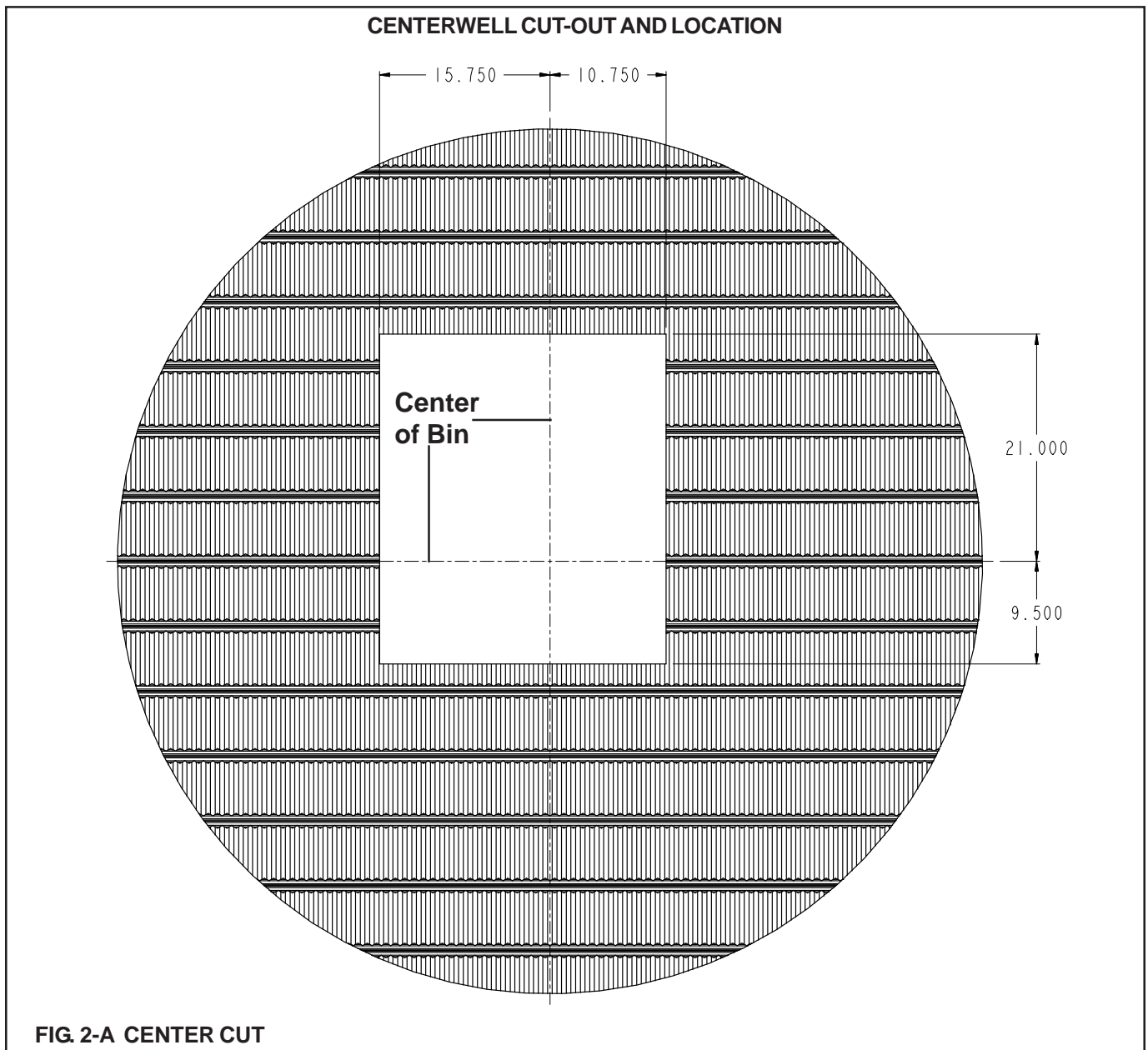

FIG. 1- A FLOOR VIEW

2. POWER SWEEPS IN BINS WITH RAISED METAL FLOORS

For bins with raised metal floors, it is necessary to cut openings in the floor for the Centerwell and Intermediate Wells.

- A. Make sure the metal floor is high enough above the concrete base so there is space for the wells. It would be convenient to complete assembly of the bin floor as the power sweep is being installed for better access to components under the floor.
- B. Locate the center of the bin and make a cut-out in the bin floor for the Centerwell.



- C. Place the Centerwell into position, with the vertical shaft between the two halves of the gearbox at the center of the bin. Place suitable supports under the Centerwell to hold it in position.

3. INTERMEDIATE WELL INSTALLATION

A. Cut openings in the bin floor for the Intermediate wells. (See figure below.) The number of wells depends on bin size. The distance between Intermediate wells and the Centerwell should be equal.

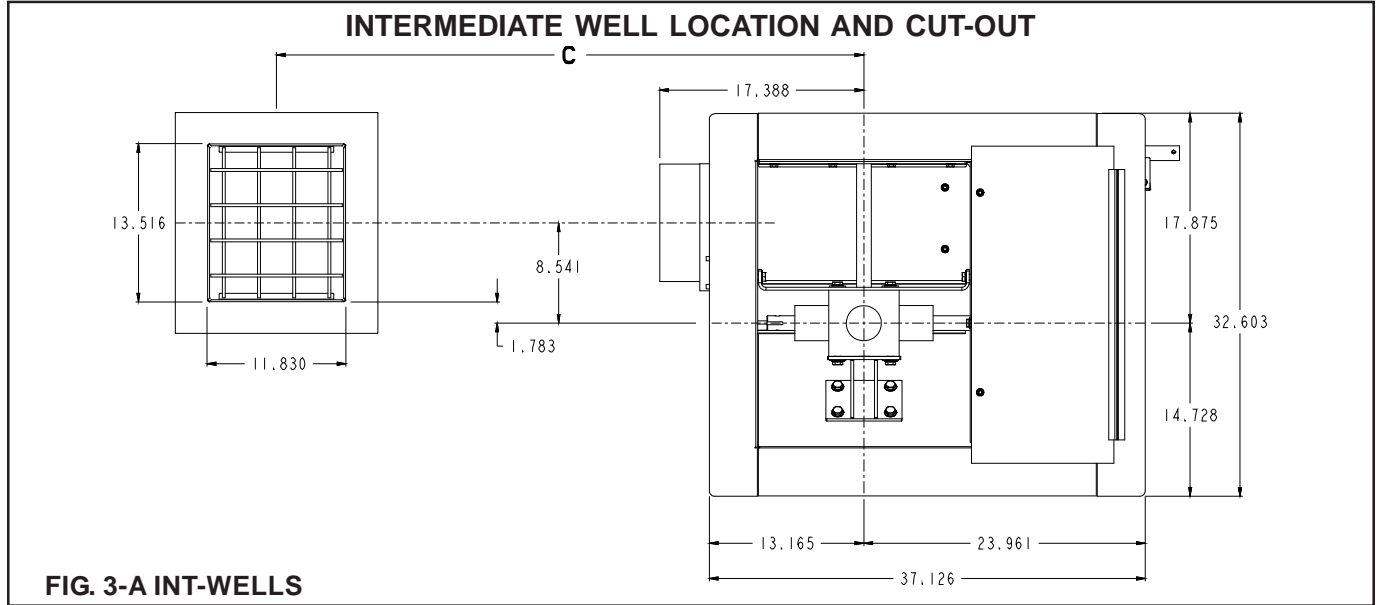

BIN SIZE	NUMBER OF INTERMEDIATE WELLS	DISTANCE FROM CENTER OF BIN TO WALL (A)	DISTANCE BETWEEN CENTERWELL AND FIRST INTERMEDIATE WELL (B)	DISTANCE BETWEEN WELLS (C)	DISTANCE FROM CENTER OF BIN TO ANGLE RING (D)	DISTANCE FROM BIN WALL TO ANGLE RING
36'	3	17' 10-7/8"	36.363"	53.75"	250.888"	36.013"
42'	4	20' 10-11/16"	32.613"	50.00"	286.638"	35.950"
48'	4	23' 10-1/2"	39.863"	57.25"	322.388"	35.888"
54'	4	26' 10-1/4"	47.113"	64.50"	358.388"	36.138"
60'	5	29' 10-1/8"	42.363"	59.75"	394.138"	36.013"
72'	6	35' 9-3/4"	44.113"	61.50"	465.638"	35.888"
75'	6	37' 3-5/8"	46.613"	64.00"	483.638"	36.013"
78'	6	38' 9-9/16"	49.113"	66.50"	501.638"	36.075"

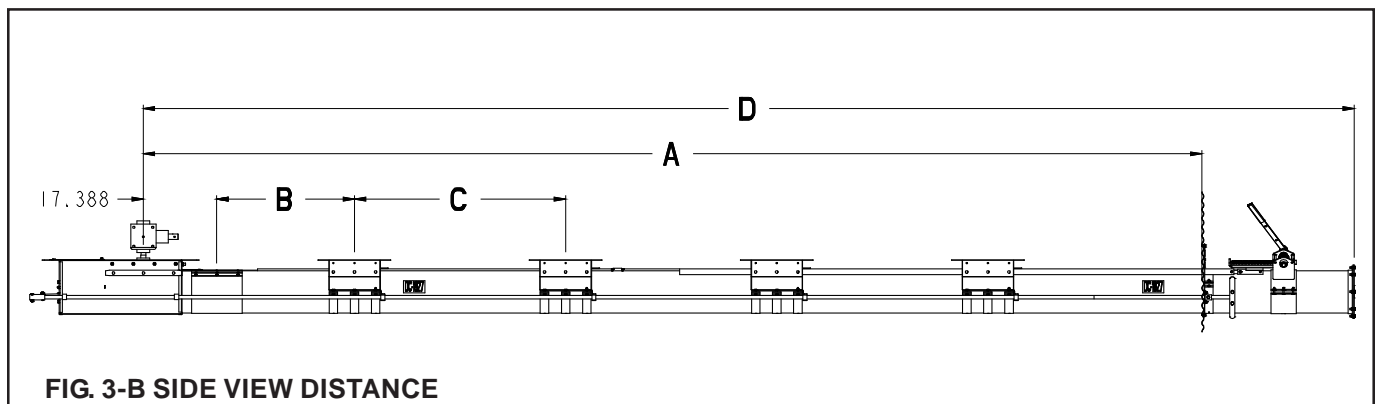

4. UNLOAD TUBE ASSEMBLY INSTALLATION

- A. Cut an opening in the bin wall for the unloading tube to pass through. The hole should be approximately 13 ½" in diameter, 6" below the level of the floor and in line with the Centerwell tube.

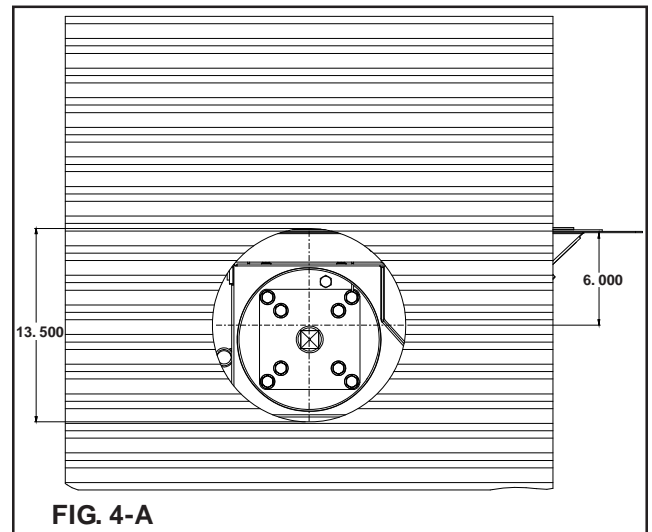

- B. From inside the bin, insert the angle ring end of the Unload Tube Assembly through the hole in the bin sidewall.
- C. On bins > 60' in diameter, place the angle ring end of the outer Unload Tube Assembly through the hole in the bin sidewall, and then place the inner Unload Tube Assembly into place.

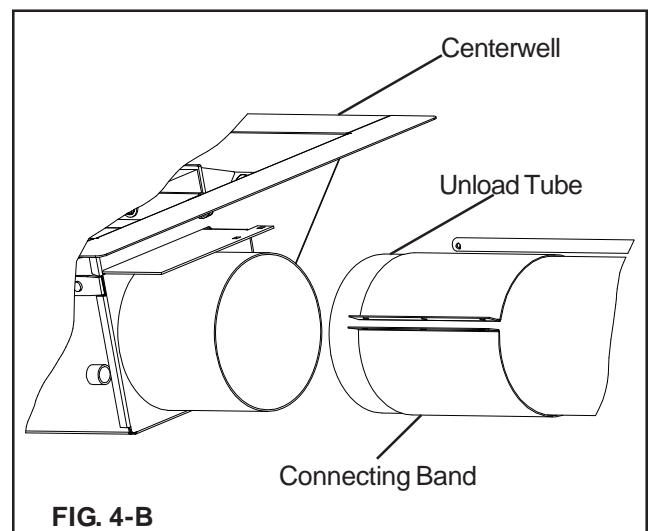

NOTE

Before installing the Unload Tube Assembly, remove the Unload Flight from inside of the tube. On 36' and 42' diameter bins, the Clutch Control Rod is shipped inside the Unload Flight.

- D. Place the 12" Connecting Band onto the end of the Unload Tube Assembly closest to the Centerwell.

4. UNLOAD TUBE ASSEMBLY INSTALLATION (Cont.)

- E. Position the Unload Tube flush against the Centerwell tube.

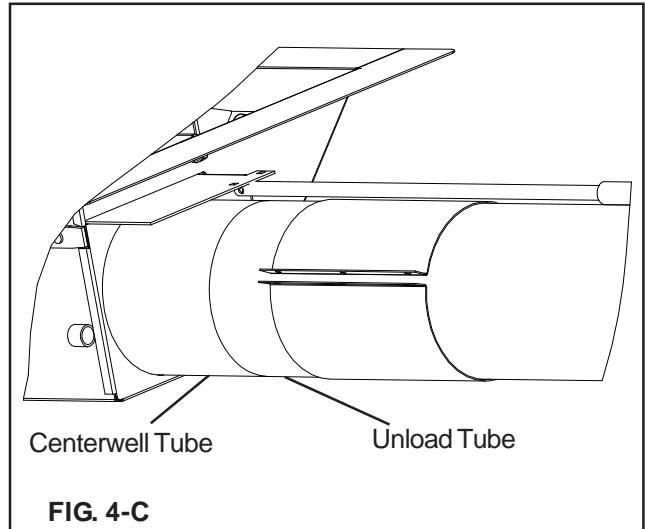

- F. Slide the Connecting Band until it is equally positioned over both the Unload Tube and the Centerwell tube. Position the Connecting Band so that it will not interfere with the control rods.

- G. Secure the Connecting Band with three (3) 5/16" x 1-1/2" Hex bolts and Serrated Flange Nuts, making sure the Intermediate Wells are level with the Centerwell.

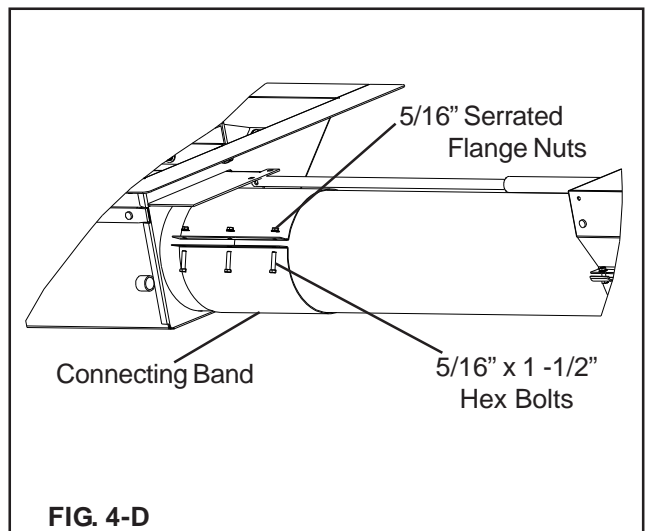

5. OUTER UNLOAD TUBE ASSEMBLY INSTALLATION

- A. On bins > 60' in diameter, loosen or unbolt the 30" Connecting Band from the outer Unload Tube Assembly.

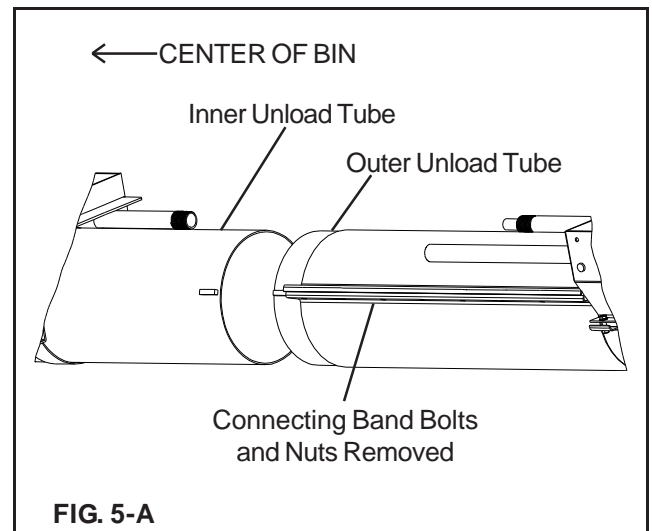

- B. Position the outer Unload Tube Assembly flush against the inner Unload Tube Assembly, aligning the two keyways so that they are inline, and making sure all of the Intermediate Wells are level with the Centerwell.

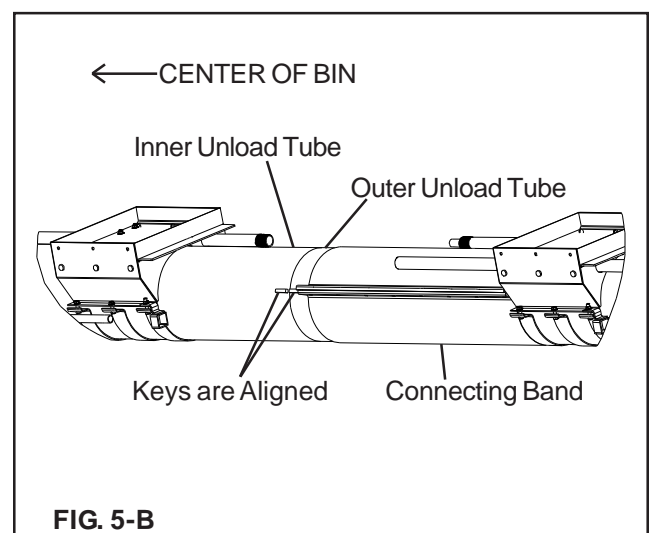

- C. Slide the Connecting Band until it is equally positioned over both the Unload Tube Assemblies. Position the Connecting Band so that it is aligned with the keyways on the Unload Tubes.
- D. Secure the Connecting Band with eight (8) 3/8" x 1-1/2" Hex bolts and Stover nuts.

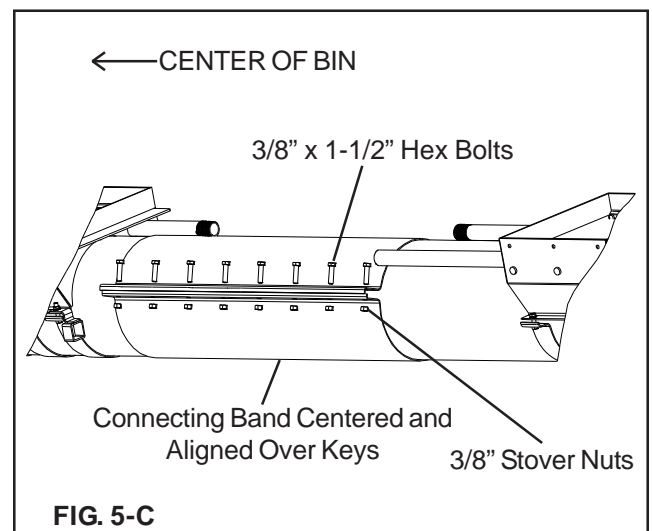

5. OUTER UNLOAD TUBE ASSEMBLY INSTALLATION (Cont.)

- E. Thread the 1" External Control Pipe Coupler onto the Intermediate Control Rod. Also thread the 1/2" Internal Control Pipe Coupler onto the Centerwell Control Rod.

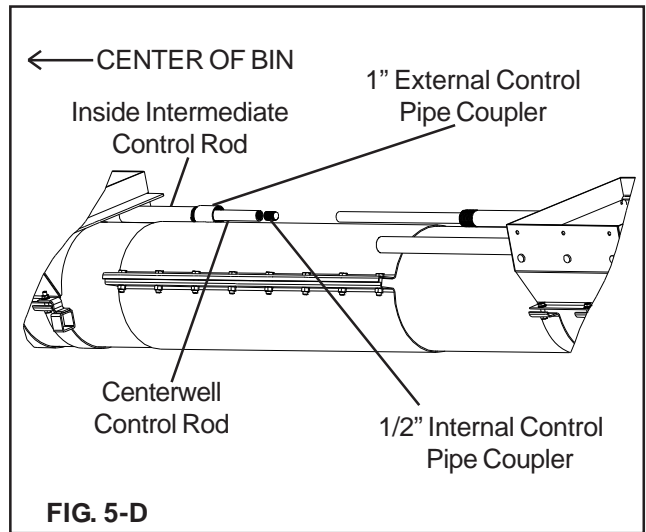

- F. Thread the other Centerwell Rod onto the 1/2" coupler and leave it slightly loose. Also thread the other Intermediate Rod onto the 1" coupler.

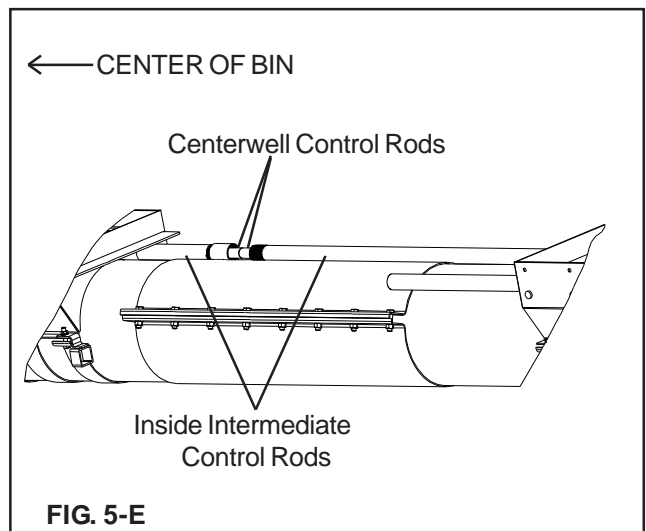

6. CENTERWELL CONTROL GATE ASSEMBLY

- A. Close the Centerwell Control Gate completely.
- B. Align the Centerwell Control Rod between the two holes in the Centerwell Control Gate.
- C. Attach the 1/2" Control Rod Clamp to the Centerwell Control Rod by sliding 5/16" x 1-3/4" roll pin through the Clamp and the Rod.
- D. Fasten the Control Rod Clamp to the bottom side of the Centerwell Control Gate by using two (2) 5/16" x 3/4" Carriage Bolts, flat washers, and Serrated Flange nuts. Install the nuts so that they secure the roll pin in place.

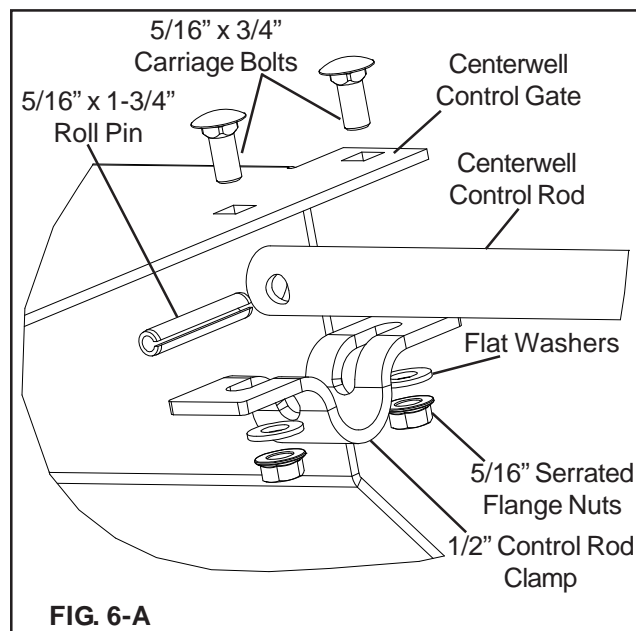

- E. Adjust the Centerwell Control Rod and the Intermediate Control Rods so that the second hole on the Centerwell Control Rod and the hole on the Intermediate Control Rod are aligned, and that they are both horizontal.

NOTE

This alignment is important for proper gate control with the Rack & Pinion.

- F. Make sure all connections are tight.

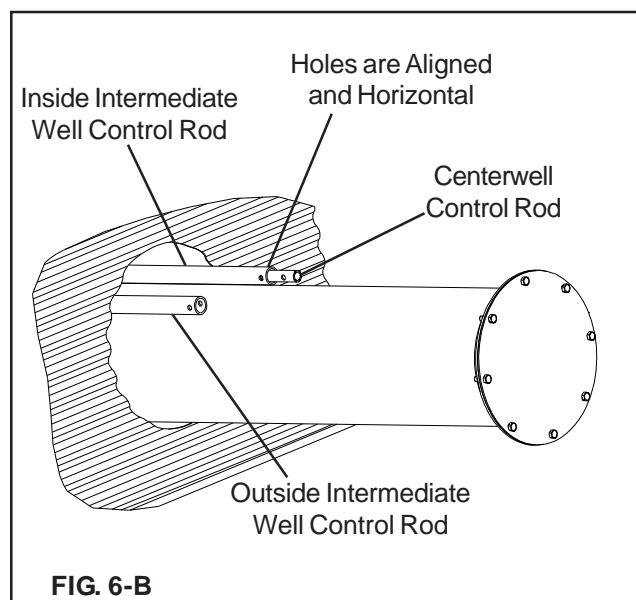

7. BIN FLANGE INSTALLATION

- A. Attach the upper and lower Bin Flanges to the Unload Tube Assembly using two (2) 5/16" x 1-1/2" Hex bolts, and Serrated Flange nuts.

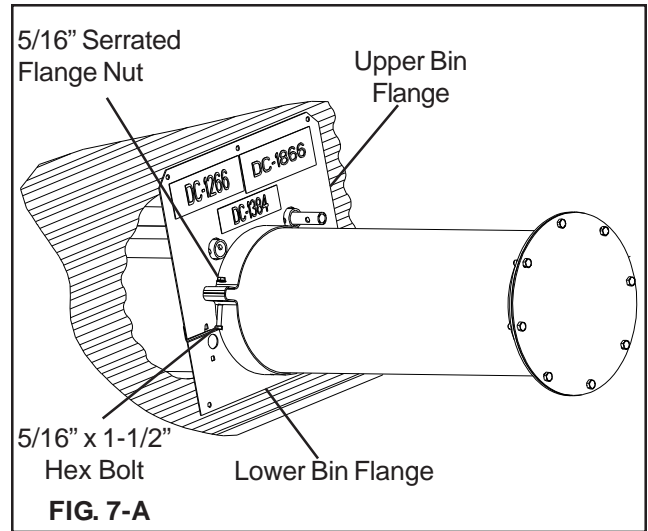

- B. Install the Clutch Control Pipe Position Lock to the lower Bin Flange using two (2) 5/16" x 3/4" Carriage bolts and Serrated Flange nuts. Install the Carriage bolt heads on the backside of the lower Bin Flange so they will be next to the Bin Wall when the Bin Flanges are attached to the Bin.

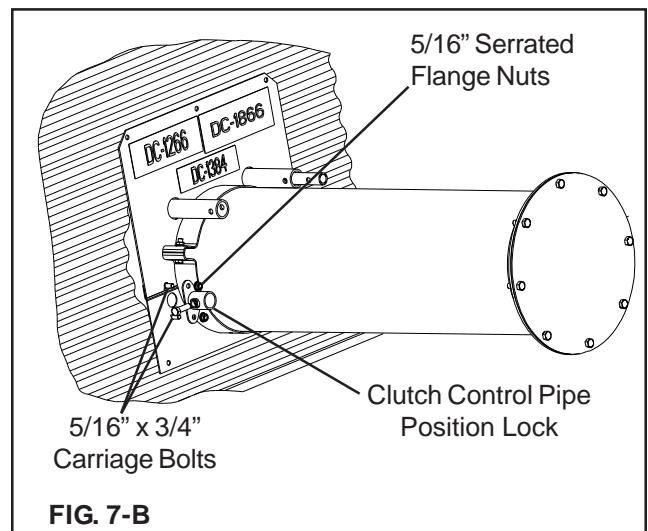

- D. Slide the Bin Flanges flush up to the Bin Wall and tighten the two bolts connecting the two Flanges.

- E. Drill into the Bin Wall through the holes located in the four (4) corners of the Bin Flanges. Fasten the Bin Flanges to the Bin Wall using four (4) 5/16" x 3/4" Bin bolts and Serrated Flange nuts.

- F. Drill the remaining hole into the Bin Wall and attach the remaining 5/16" x 3/4" Bin bolt and Serrated Flange nut.

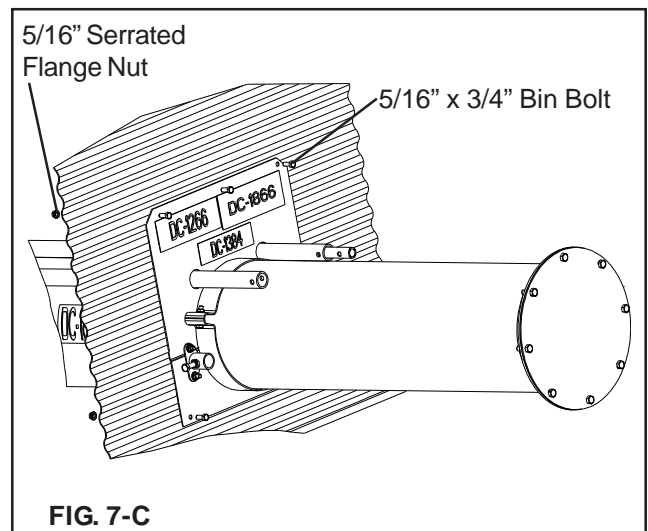

8. RACK & PINION INSTALLATION

- A. Make sure that all gates are fully closed.
- B. Pin the Inside Intermediate Control Rod to the Centerwell Control Rod, by using a 5/16" x 1-3/4" Hex bolt and Hex nut through the aligned hole.

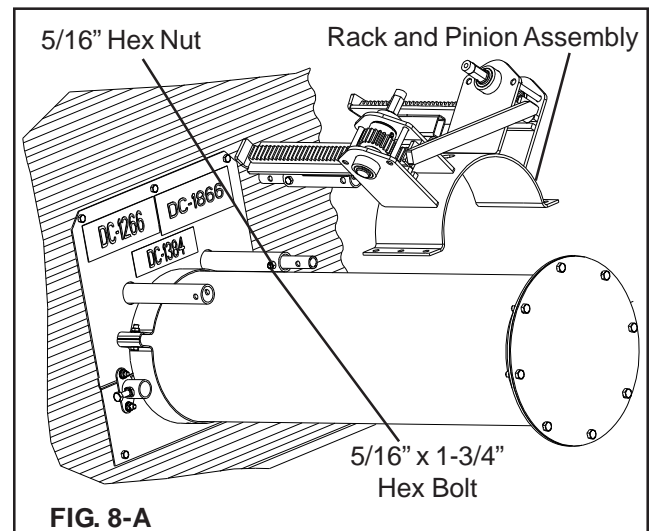

- C. Slip the Rack & Pinion tube over the Centerwell Gate Control Rod, and slip the Outside Intermediate Well Adapter pipe into the Outside Intermediate Control Rod. Align the holes to the Centerwell Control Rod and the Outside Intermediate Well Control Rod with the matching holes on the Rack and Pinion. Make sure the Rack & Pinion is fully extended towards the bin wall.
- D. Attach the Rack & Pinion to the Control Rods using two (2) 5/16" x 1-3/4" Hex bolts and Hex nuts.

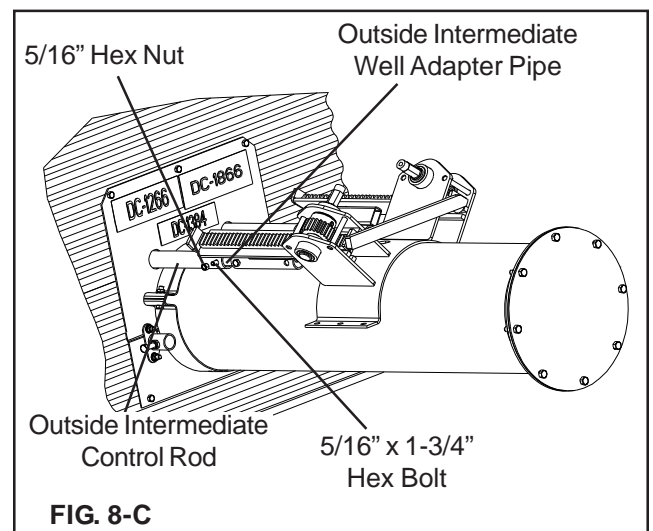
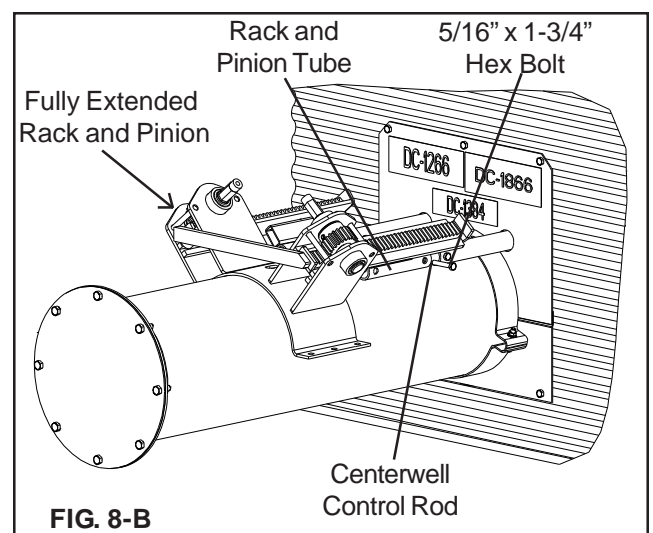

8. RACK & PINION INSTALLATION (Cont.)

- E. With the Rack & Pinion fully extended towards the bin wall, attach the Half Band with six (6) 5/16" x 1-1/2" Hex bolts, flat washers, and Serrated Flange nuts.

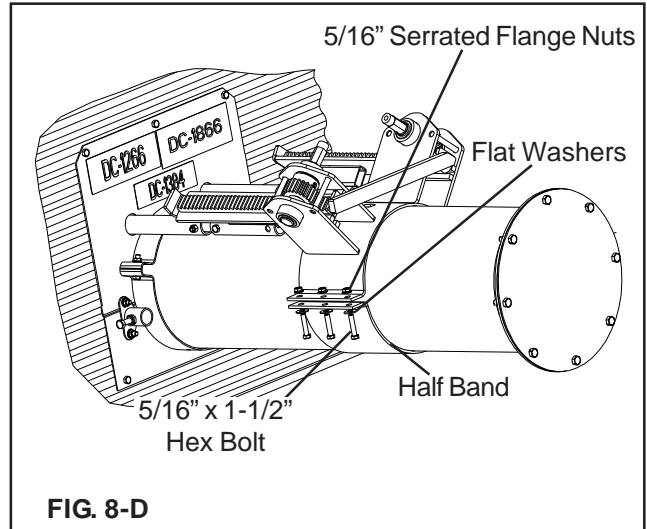

- F. Slide the 3/4" Wrenches over the shafts on the Rack & Pinion, making sure the collar faces the gears. Fasten the Wrenches with the two (2) 3/8" x 3/4" Flange bolts and flat washers.

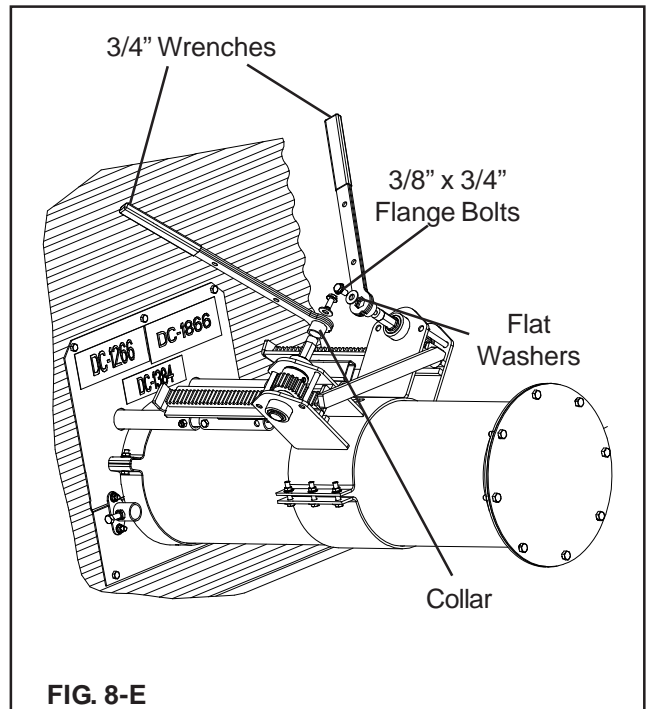

NOTE

On 36' diameter bins, install the Rack & Pinion using the steps above, noting that there is no Outside Intermediate Control Rod to attach to, and only one Rack to operate the Center and Intermediate Wells.

9. CLUTCH CONTROL INSTALLATION

- A. Install the longest section of the 1/2" Clutch Control Rod to the Clutch Control Arm on the Centerwell. Make sure that it is contained in the square Clutch Control Pipe Guides on the Intermediate Wells. Bolt the Rod to the Arm with a 5/16" x 1-3/4" Hex bolt and Nylock nut.

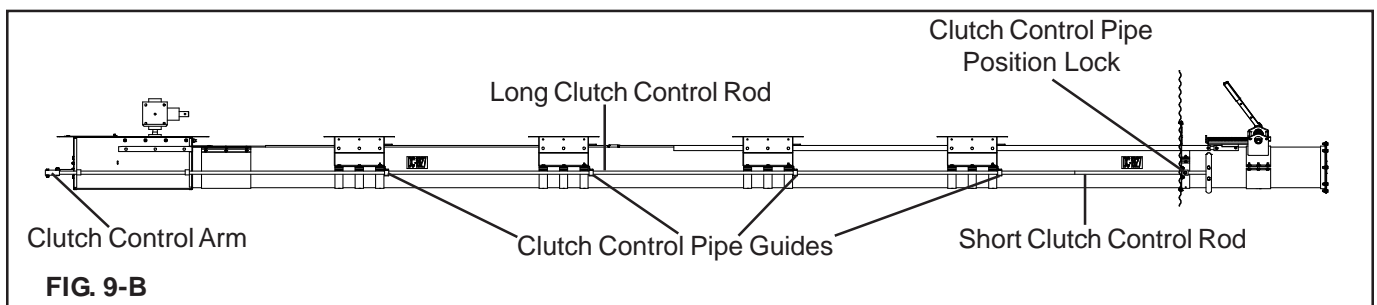
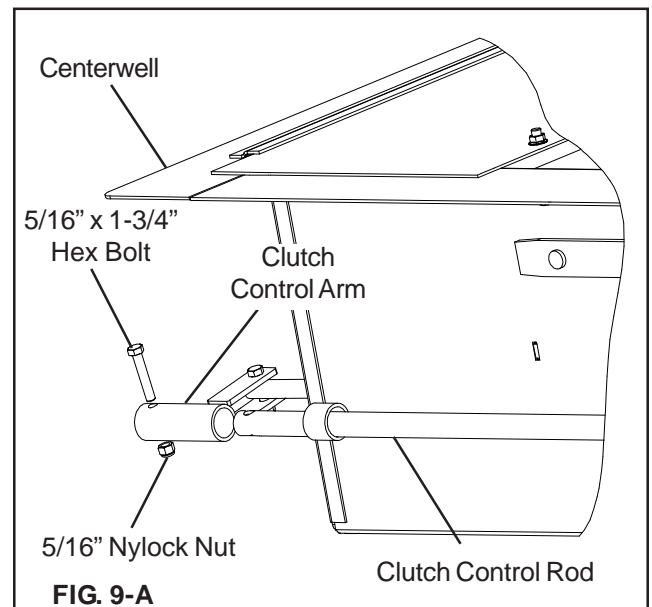

NOTE

On 36' and 42' diameter bins, the Clutch Control Rod will come preassembled, and shipped inside the Unload Flight.

- B. Connect the two Clutch Control Rods by threading the 1/2" Internal Pipe Connector halfway onto the Rod attached to the Centerwell. Bring the other Clutch Control Rod up to it by running the Rod through the Clutch Control Pipe Position Lock in the Bin Flange, threaded end first, and making sure that the Rod is contained by the Guides on the Intermediate Wells. Then thread the Rod onto the remaining threads on the Coupler.

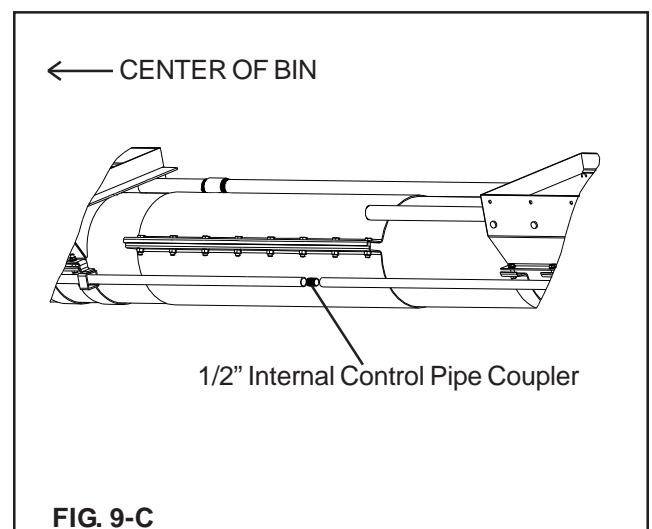

9. CLUTCH CONTROL INSTALLATION (Cont.)

- C. Attach the 1/2" Control Rod Clamp to the Control Rod by inserting the 5/16" x 1-3/4" long roll pin through the Clamp and Control Rod.
- D. Fasten the Clutch Handle to the Clamp using two (2) 5/16" x 3/4" Carriage bolts, flat washers, and Serrated Flange Nuts. Install the nuts so that they secure the roll pin in place.

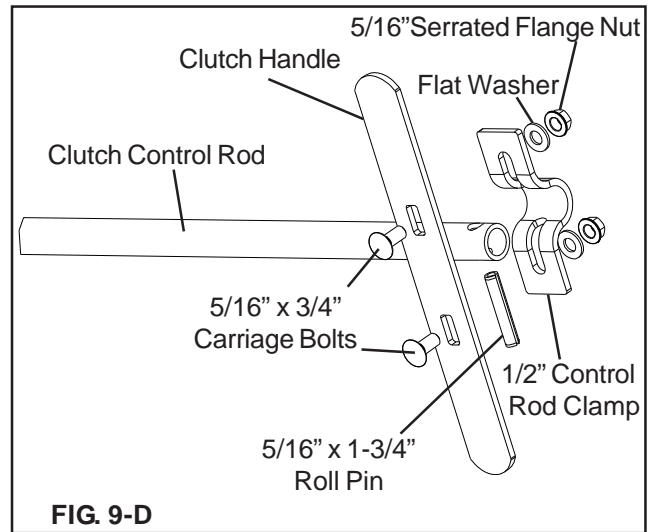

- E. Check the operation of the Clutch Rod by pulling the handle to engage the clutch and then pushing the handle to disengage it. The Clutch Control Pipe should slide freely. Lock the Control Pipe into the disengaged position by tightening the bolt on the Clutch Control Pipe Position Lock that is attached to the Bin Flange.

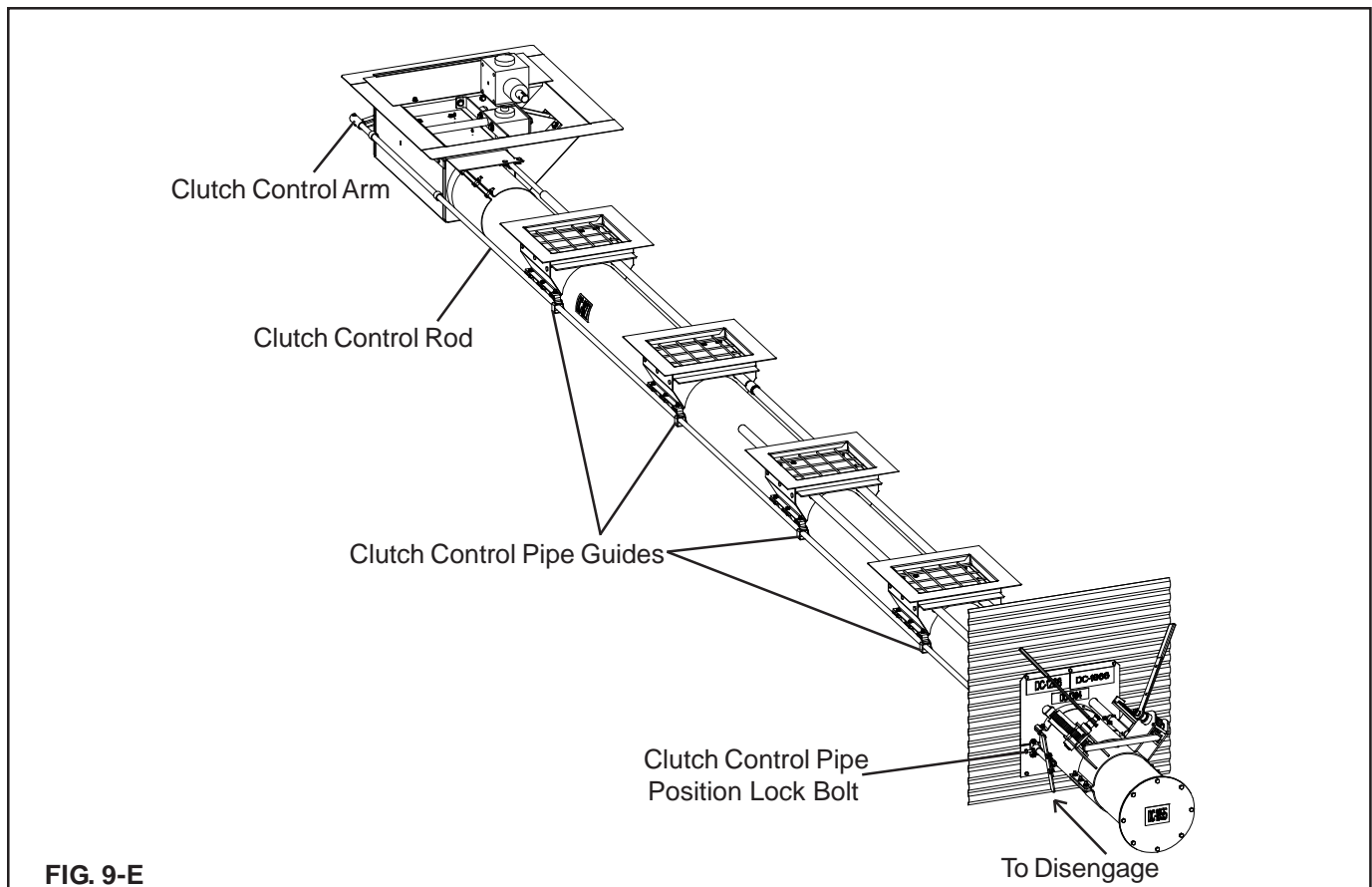

10. ASSEMBLING AND INSTALLING THE UNLOAD FLIGHT

- A. Begin by removing the Unload Tube Assembly End Cap if you have not done so already.

NOTE

On 36' and 42' diameter bins, the Unload Flight is one piece. Skip Steps B – D.

- B. Locate the Inner Unload Flight. One end of this Flight should have a Square bushing; the other end has a Round bushing with two (2) cross-drilled holes. Attach the 1-1/2" OD x 9-1/2" Connecting Shaft to the Inner Unload Flight using two (2) 1/2" x 3-1/2" Grade 8 Hex bolts and Stover nuts.
- C. Align the Outer Unload Flight to the Inner Unload Flight, making sure that the Dura-Edge on both Flights are as continuous as possible, the angle between both faces being less than 180°, and without overlapping.

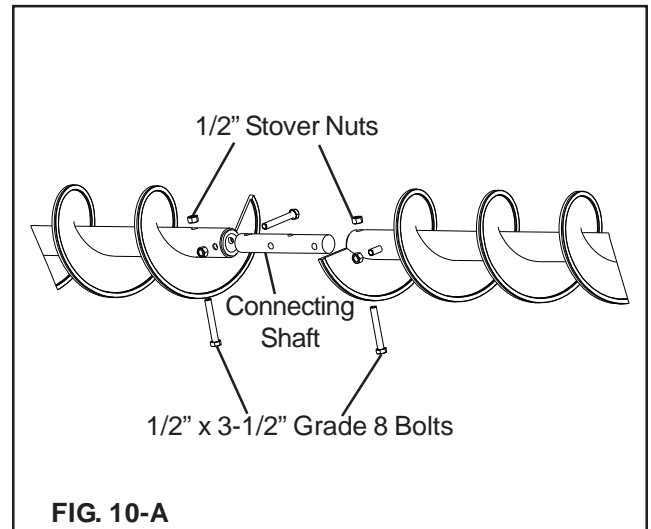

FIG. 10-A

NOTE

Overlapping the Flights, or having an angle between the ribbon faces be greater than 180°, will result in reduced unload capacity.

- D. Attach the Discharge Unload Flight to the Connecting Shaft using two (2) 1/2" x 3-1/2" Grade 8 bolts and Stover nuts.

10. ASSEMBLING AND INSTALLING THE UNLOAD FLIGHT (Cont.)

- E. Insert the Unload Flight into the Unload Tube with the Square bushing end facing the Centerwell, and the Round bushing end facing the Discharge End of the Tube.

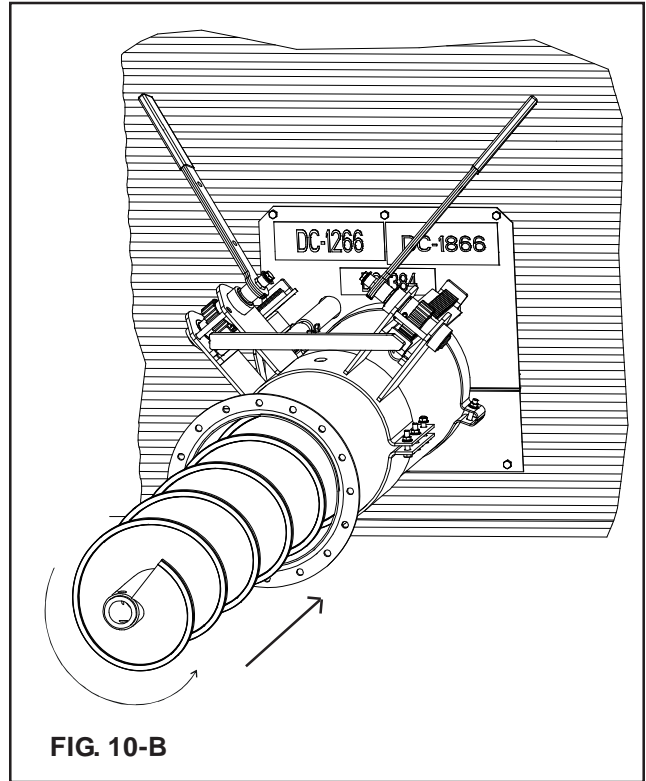

- F. When the Unload Flight is approaching the Centerwell Square Shaft, it will be necessary to rotate the Flight counter-clockwise to get it to seat properly on the Square Shaft. When the Flight is properly seated, the Flight should be entirely inside the Unload Tube. It may be necessary to pull the Flight out a small amount and attempt this step multiple times in order to seat the Flight properly.
- G. On an initial install with an empty bin, the installer should open the Centerwell Gate and enter the bin to check and see that the Flight is seated. Once they have seen that it has seated, they will know the proper position the Flight is in on the Discharge End, when seated properly.

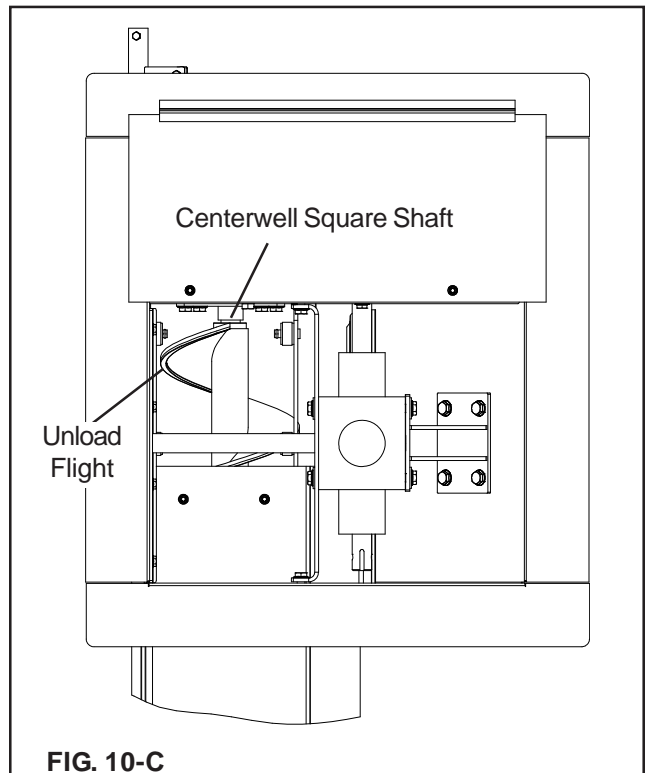

11. INSTALLING THE SWEEP FLIGHTING

- A. Attach the U-Joint to the Centerwell Gearbox Shaft using a 1/4" x 1-1/4" Square Key, and a 3/8" x 3" Hex bolt and Stover nut.

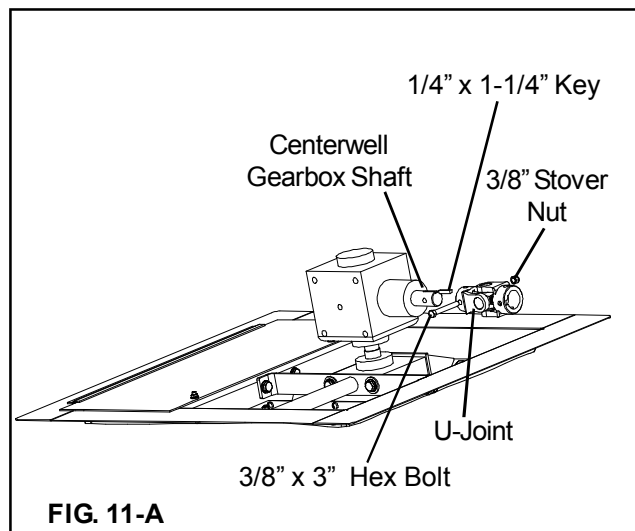

- B. Attach the U-Joint Flight Shaft to the U-Joint using a 3/8" x 1-1/2" Square Key, and a 1/2" x 3-1/4" Hex bolt and Stover nut. Tighten both setscrews after installation of keys.

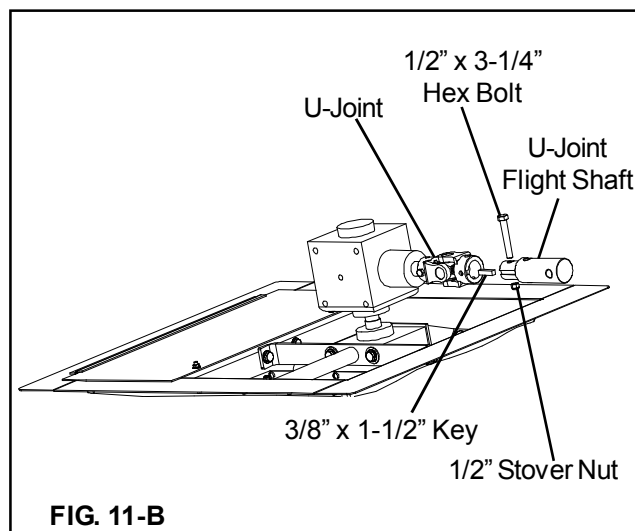

NOTE Use the Table below to determine the quantity and lengths of the Sweep Flights and Back Shields for the given Bin Diameter.

Sweep Flights and Back Shields		
Bin Dia.	Quantity	Length
36	1	6' 10"
	1	8' 4"
42	1	8' 4"
	1	9' 10-1/4"
48	1	5' 4"
	1	6' 10"
54	1	8' 10-1/2"
	2	5' 4"
60	1	9' 4"
	2	8' 4"
72	1	9' 4"
	2	6' 10"
	1	8' 4"
75	3	9' 4"
	1	8' 4"
78	2	8' 4"
	1	9' 4"
	1	9' 10-1/4"

11. INSTALLING THE SWEEP FLIGHTING (Cont.)

- C. Fasten the first section of Sweep Flight to the U-Joint Flight Shaft with two (2) 5/8" x 4" Grade 8 bolts and Stover nuts. Make sure that the Dura-Edge side of the Sweep Flight faces the center of the Bin.

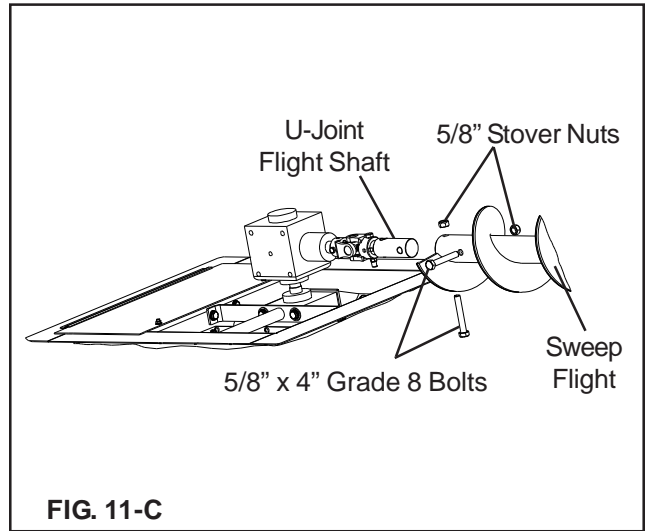

- D. Next, bolt the 2" OD x 11-1/2" Connecting Shaft to the Sweep Flight with two (2) 5/8" x 4" Grade 8 bolts and Stover nuts.

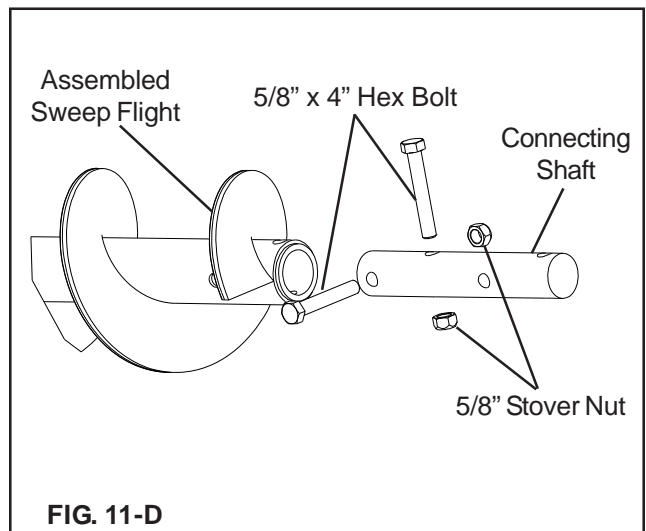

- E. Place the Bearing Stand Assembly onto the Connecting Shaft.

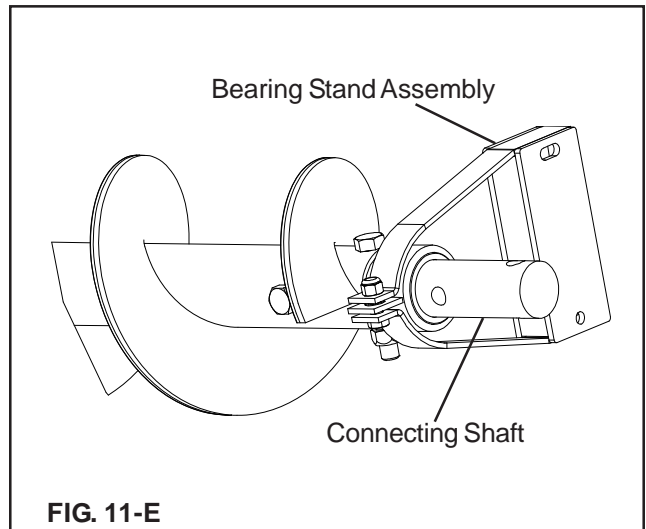

11. INSTALLING THE SWEEP FLIGHTING (Cont.)

- F. Align the next section of Sweep Flight making sure that the Dura-Edge on both Flights are as continuous as possible, the angle between both faces being greater than 90°, and less than 180°, and without overlapping.

NOTE

Overlapping the Flights, or having an angle between the ribbon faces be less than 90° or greater than 180°, will result in reduced unload capacity.

- G. Install the next section of Sweep Flight. Bolt it to the Connecting Shaft using two (2) 5/8" x 4" Grade 8 bolts and Stover nuts.
- H. Repeat Steps D - G for additional sections of Sweep Flight.
- I. Attach the Gearbox Pivot Bracket onto the Gearbox with four (4) 1/2" x 1-1/4" Flange bolts and flat washers.

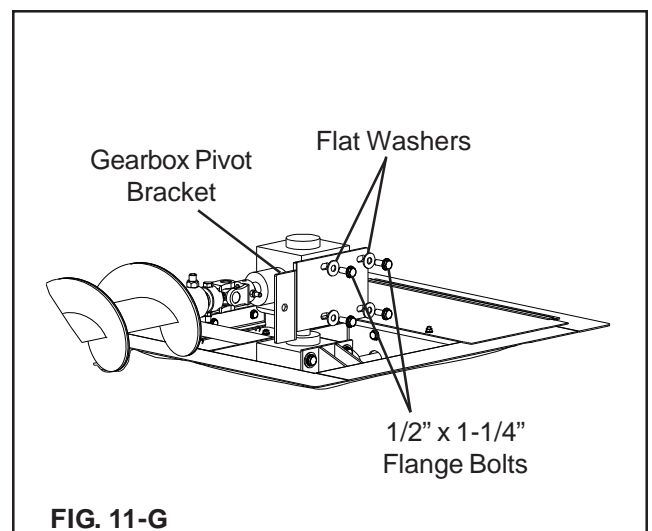
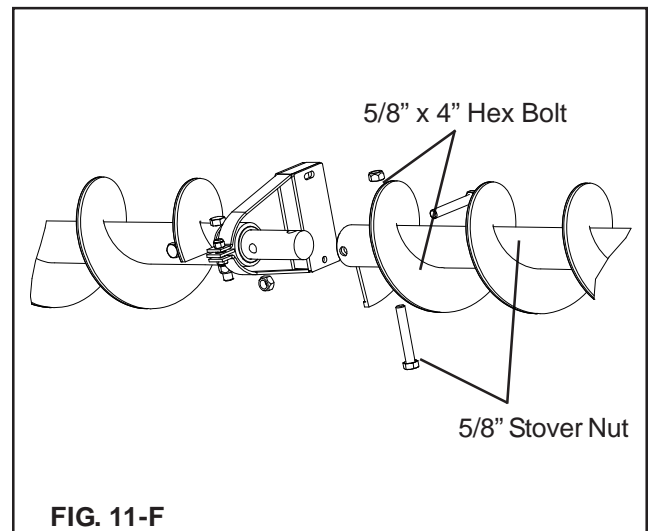

- J. Attach the Shield Pivot Bracket to the Gearbox Pivot Bracket using a 5/8" x 1-1/2" Hex bolt and Nylock nut.

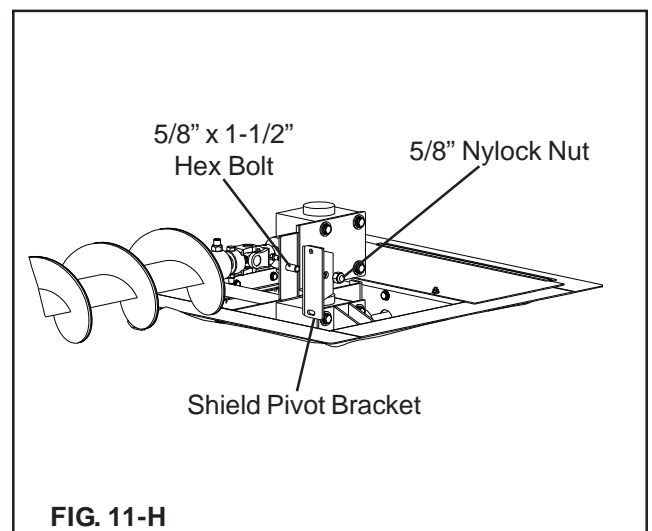

11. INSTALLING THE SWEEP FLIGHTING (Cont.)

- K. Bolt the first section of Back Shield to the Shield Pivot Bracket with two (2) 3/8" x 1- 1/2" Grade 8 bolts, four (4) flat washers, and two (2) Nylock nuts.

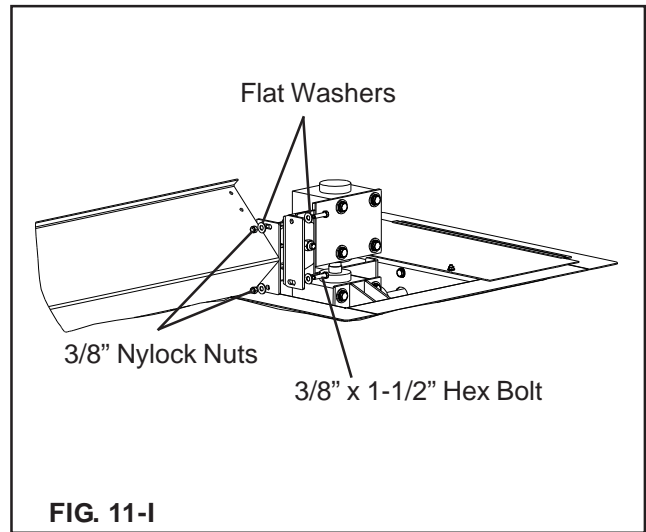

- L. Attach the second section of Back Shield to the Bearing Stand Assembly and the first section of Back Shield with two (2) 3/8" x 3" Carriage bolts, flat washers and Nylock nuts.

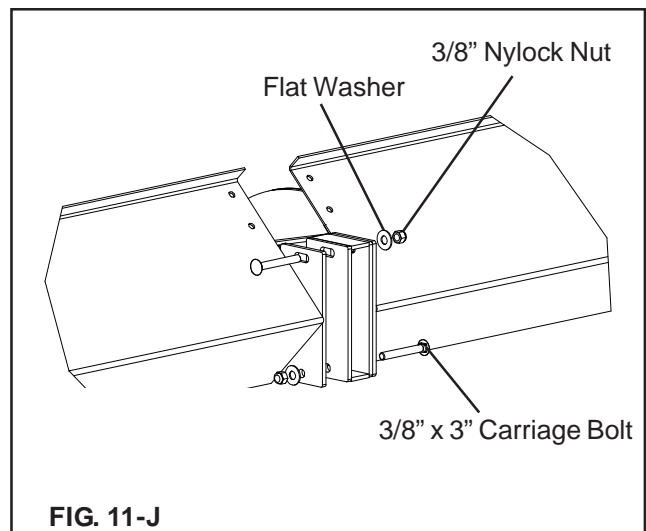

- M. Bolt the Shield Splice Plate to complete the connection of the two Back Shields. Use four (4) 5/16" x 3/4" Hex bolts, flat washers, and Serrated Flange nuts.

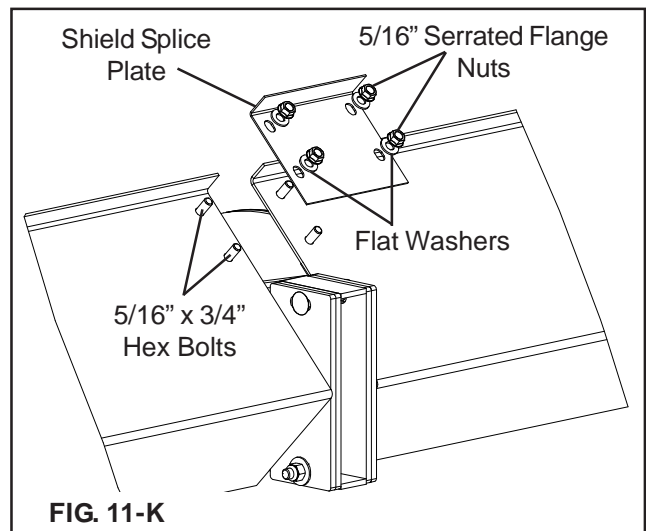

11. INSTALLING THE SWEEP FLIGHTING (Cont.)

- N. Attach the second and third sections of Back Shield to the Bearing Stand Assembly together with the Carrier Wheel Assembly. Use two (2) 3/8" x 3-1/2" Hex bolts, four (4) flat washers, and two (2) Nylock nuts.

NOTE

Sweep Arms with three (3) or more Flight and Shield sections, a Carrier Wheel Assembly is used. The Carrier Arm should be installed after the first two (2) sections of Flight and Shield.

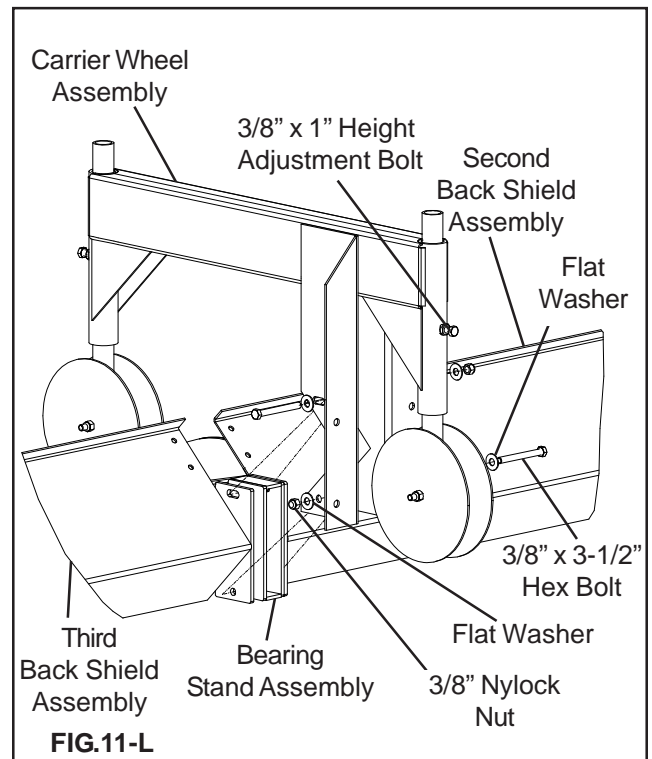

- O. Bolt the Shield Splice Plate to complete the connection of the two Back Shields. Use four (4) 5/16" x 3/4" Hex bolts, flat washers, and Serrated Flange nuts.
- P. The Carrier Wheel Assembly height can be adjusted by using the 3/8" x 1" bolts on the Sweep Carrier Body.
- Q. Repeat Steps L & M until all Shield sections are assembled.

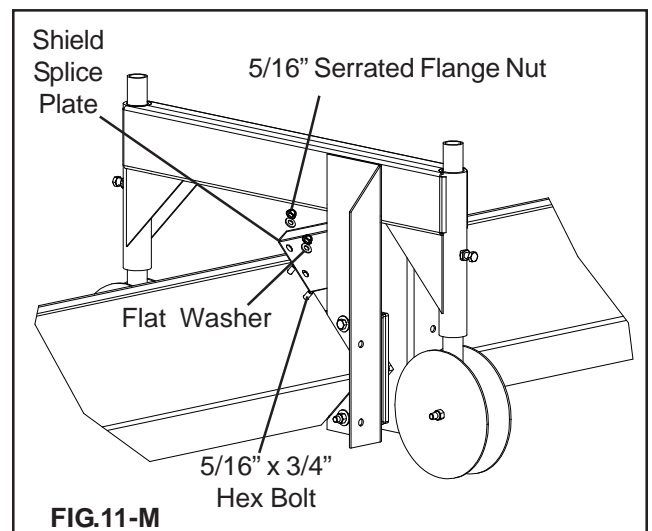

12. SWEEP WHEEL INSTALLATION

- A. Join the Sweep Wheel Housing Bracket and the Mounting Bracket with Anchor Loop together with two (2) 3/8" x 1-1/2" Grade 8 bolts, four (4) flat washers, and two (2) Nylock nuts.

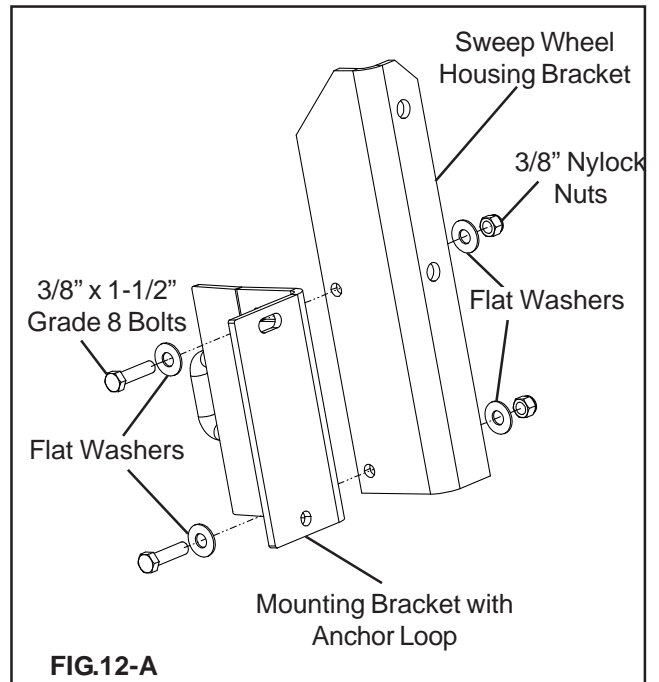

- B. Attach the assembly to the final Back Shield with two (2) 3/8" x 1-1/2" Grade 8 bolts, four (4) flat washers, and two (2) Nylock nuts.

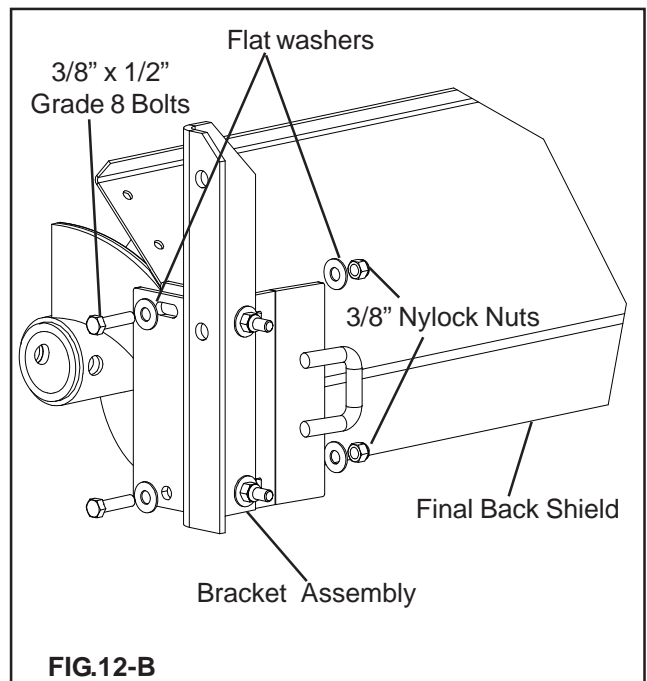

12. SWEEP WHEEL INSTALLATION (Cont.)

- C. (A) Remove the bottom three (3) $\frac{1}{2}$ " x $\frac{3}{4}$ " Hex bolts and lock washers on the outside of the Enclosed Chain Drive Assembly. (B) Attach the Input Shaft of the Enclosed Chain Drive Assembly to the final Sweep Flight using a $\frac{5}{8}$ " x 4" Grade 8 bolt and Stover nut. (C) Attach the Sweep Wheel Housing Bracket to the Enclosed Chain Drive Assembly with two (2) of the previously removed $\frac{1}{2}$ " x $\frac{3}{4}$ " Hex bolts and lock washers.

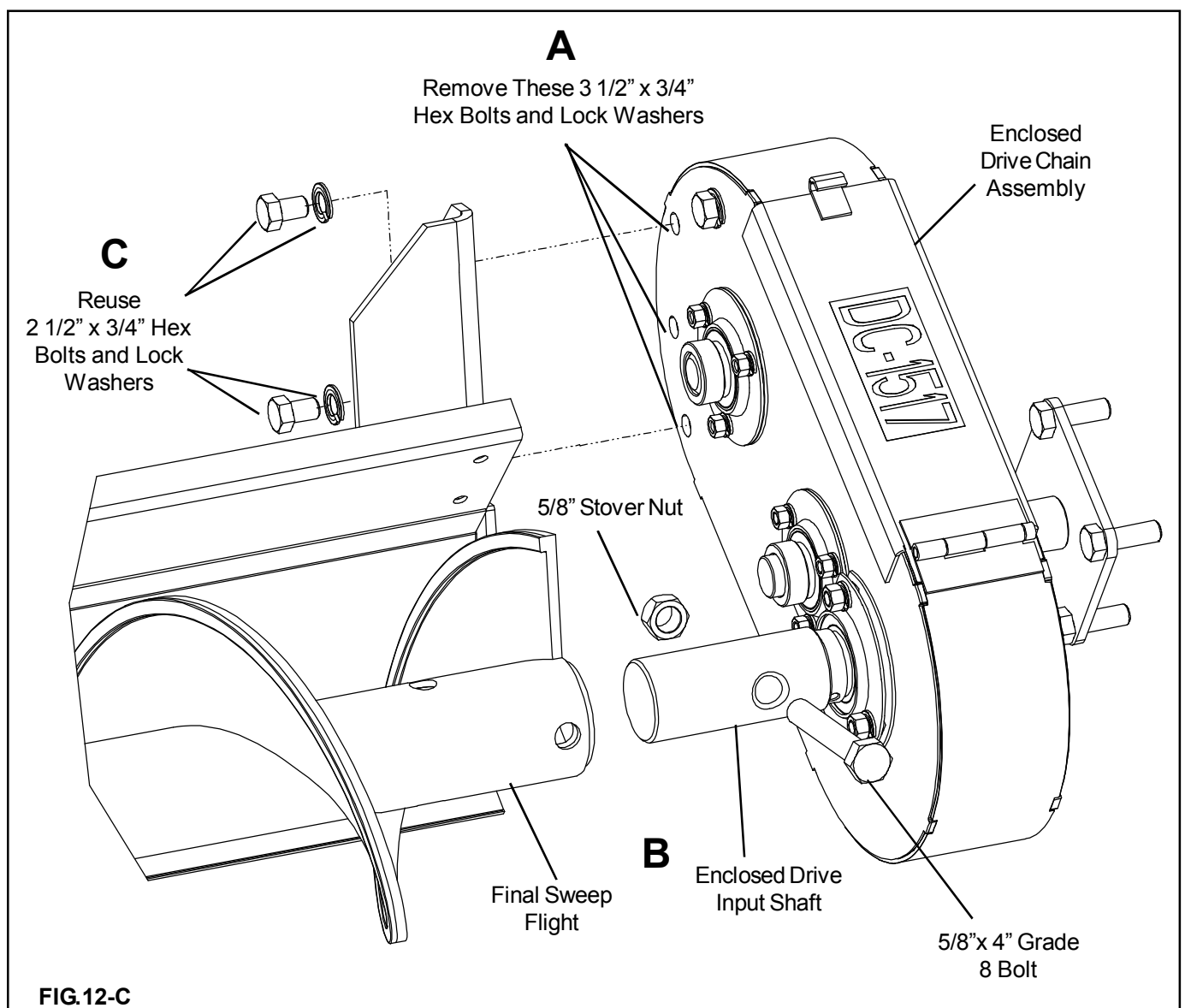

12. SWEEP WHEEL INSTALLATION (Cont.)

- D. Bolt the Segmented Rubber Wheel to the Enclosed Chain Drive Assembly Wheel Shaft Weldment with four (4) 1/2" Nylock nuts.
- E. Make final adjustments to the Back Shields and mounting brackets, and tighten all hardware. Remember to leave the Pivot bolt at the Gearbox loose enough to pivot.
- F. Inspect the "DANGER" decals on the Enclosed Chain Drive Assembly Housing and the Back Shields to insure legibility. If the decal cannot easily be read or is missing, order a new decal immediately from your dealer.
- G. Open the Enclosed Chain Drive Lid and inspect the chain. The chain should have a light coat of oil on it. If it does not, lightly coat the chain with oil.
- H. Close and secure the Enclosed Chain Drive Lid.

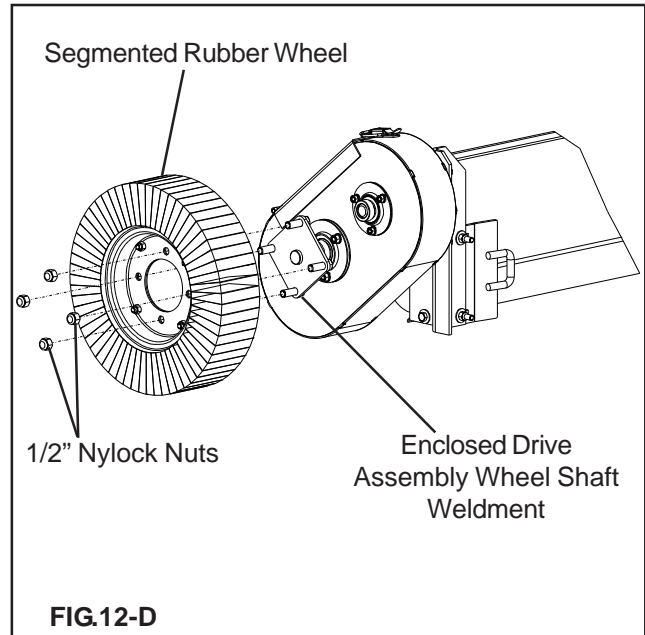

⚠ DANGER

Do NOT Operate with the Enclosed Chain Drive Lid open.

NOTE

A single section of Sweep Flight and Back Shield, or just a few sections, can be used alone without all the other sections. Install the Sweep Wheel at the end of the last section being used.

13. MOTOR SELECTION

- A. The following horsepower recommendations are for conveyance of reasonably dry grain. Grain with moisture content above 15% will require a greater horsepower to obtain the designed capacity. The maximum possible capacity will be less with high moisture grain than it will be with dry grain. Use an electric motor of the correct size that operates at 1750 RPM. DO NOT use a motor size that is greater than what is shown for the largest bin size in your column.
- B. Consideration should be given to the proper size auger for a batch drying or any intermittent type of operation. When augers are stopped and restarted under full load, damage to the auger may result. Starting the auger at a reduced grain load will be better than starting it at full load. Startup will be easier and convey more efficiently if the auger is kept from absolute filling.

Motor Selection			
Bin Dia.	HP	Horizontal and 25° Powerheads	12" Comm. Vertical
		Belt Quantity	Belt Quantity
36'	15	3	3
42'	15	3	3
48'	15	3	3
54'	15	3	3
60'	15	3	3
72'	20	4	3
75'	20	4	3
78'	20	4	3

NOTE

The auger capacity can fluctuate greatly under a variety of different conditions. Moisture content, different commodities, the amount of foreign matter, and auger speeds affect the performance of the auger and its efficiency. Moisture content of 25% can reduce auger capacity by as much as 40% under some conditions.

⚠ DANGER

A main power disconnect switch capable of being locked only in the off position should be used. The Switch should be locked out whenever work is being done on the Direct Gear Drive Bin Sweep.

⚠ DANGER

1. Electric motors and the controls should be installed by a qualified electrician and must meet the standards set by the National Electric Code and all state and local codes.
2. A main power disconnect switch capable of being locked only in the OFF position shall be provided. This disconnect shall be locked whenever work is being done on the auger.
3. A magnetic starter should be used to protect your motor when starting and stopping the Unload system. The magnetic starter should stop the motor in case of a power interruption, conductor fault, low voltage, circuit interruption, or a motor overload. The motor must then be restarted manually. Some motors have built-in thermal overload protection. If this type of a motor is being used, use only those motors with a manual reset.
4. The motor starting controls must be located outside of the bin. Locate the motor starting controls outside of the bin, but near the bin door so the operator has full view of the operation inside the bin.
5. Disconnect the power before resetting the motor overloads.
6. Reset controls and the motor starting controls must be located so that the operator has full view of the entire operation.
7. Make certain that all electric motors are grounded.
8. Shut off and lockout the power to adjust, service, or clean the Unload system.

14. BEFORE FILLING THE BIN

- A. Read the Instructional Decal located on the Upper Bin Flange to learn how to control the Direct Gear Drive Power Sweep Well Gates.
- B. Push the Centerwell and the Intermediate Well Control Rods towards the Bin to close Well Gates.



DO NOT enter a Grain Bin unless all power driven equipment has been shut down and locked out.



NEVER enter the Bin while the sweep auger is in operation.



DO NOT enter the bin if the grain has bridged, or has flown abnormally out of the bin. Consult Figures 14-A and 14-B for a visual. Suffocation can occur if the grain suddenly breaks loose and buries the persons inside the bin.

- C. With the power shut off and locked out, enter the Bin and position the Sweep Auger along side of the Intermediate Wells.
- D. Where a Carrier Wheel Assembly is used, adjust the height so that the Sweep Arm Assembly is close to the floor, but WILL NOT contact the floor, Intermediate Well Top Flanges, or floor screws.
- E. Open the Centerwell Cover Plate, and set it aside. While observing the Clutch Components in the Centerwell, pull the Clutch Control Pipe from the outside of the bin, until the two (2) Clutch Jaws are fully engaged. Make a distinguishing mark on the Clutch Control Rod to designate the fully engaged position.
- F. Next, push the Clutch Control Pipe toward the bin to disengage the two (2) Clutch Jaws. Verify that the Clutch is fully disengaged in the Centerwell. Make a distinguishing mark on the Clutch Control Rod to designate the fully disengaged position.
- G. Tighten the Clutch Control Pipe Position Lock Out Bolt.
- I. Reinstall the Centerwell Cover Plate.

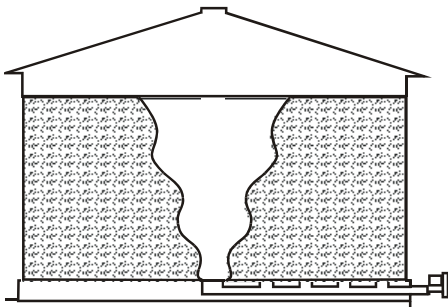

Fig. 14-A

Abnormal grain flow can easily fall and bury a person, suffocating them. **DO NOT** enter a bin with abnormal grain flow.

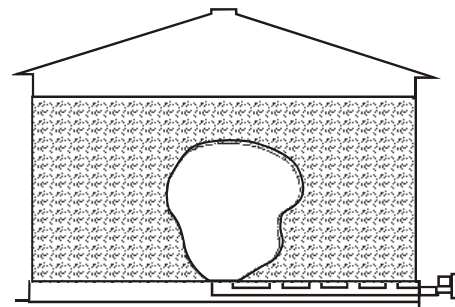

Fig. 14-B

Bridged grain can easily break loose and bury a person, suffocating them. **DO NOT** enter a bin with bridged grain.

15. PRE-START CHECKS

⚠ CAUTION

Failure to perform any and all of these pre-start checks may cause damage to the equipment and could cause **SERIOUS INJURY** or **DEATH** to those in the work area. A failure to perform any and all of these pre-start checks may also be a misuse of the equipment, which may void the warranty.

- A. Make sure that ALL belt(s) are tensioned properly.
- B. Make sure that ALL shield(s) are in place, and that the belt(s) and pulley(s) are able to move freely.

⚠ DANGER

ALWAYS keep ALL guard(s) and shield(s) in place until all the power is disconnected and locked out.

- C. Inspect the drive unit for any problems, or potential problems.
- D. Be aware of ALL emergency shutdown procedures. Two (2) people must always be in a position where the operation of the equipment can be monitored.
- E. Before starting the auger for the first time, make sure that all parts are assembled correctly according to the instructions in this manual.

⚠ WARNING

Make certain that ONLY trained operators are in the work area before operating or moving the equipment. Two (2) people must always be in a position where the operation of the equipment can be monitored.

16. NORMAL OPERATION

CAUTION

DO NOT start or stop the auger while it is under load, this may cause the auger to “jam”.

CAUTION

Failures may occur in the auger is run full before it has been polished by the grain, during the break-in period. The auger should run at a partial capacity until it becomes polished and smooth. Several hundred bushels of grain should be run before operating at full capacity.

CAUTION

Be aware of any unusual vibration or noises during the initial start-up and break-in. If anything unusual is detected, immediately shut down the auger, disconnect and lockout the power supply before servicing. Visually inspect the auger periodically during the operation.

- A. Start the unloading auger. The motor is located on the powerhead outside the bin, attached to the unload tube. To find the motor horsepower recommended for your bin size, consult the Chart on page 35, step 13A.
- B. Make sure that the Centerwell Bolt and Nut is inserted through the Rack and Pinion Tube and the Centerwell Control Rod. **NOTE: NO** bolt should be in the Inside Intermediate Well Control Rod.

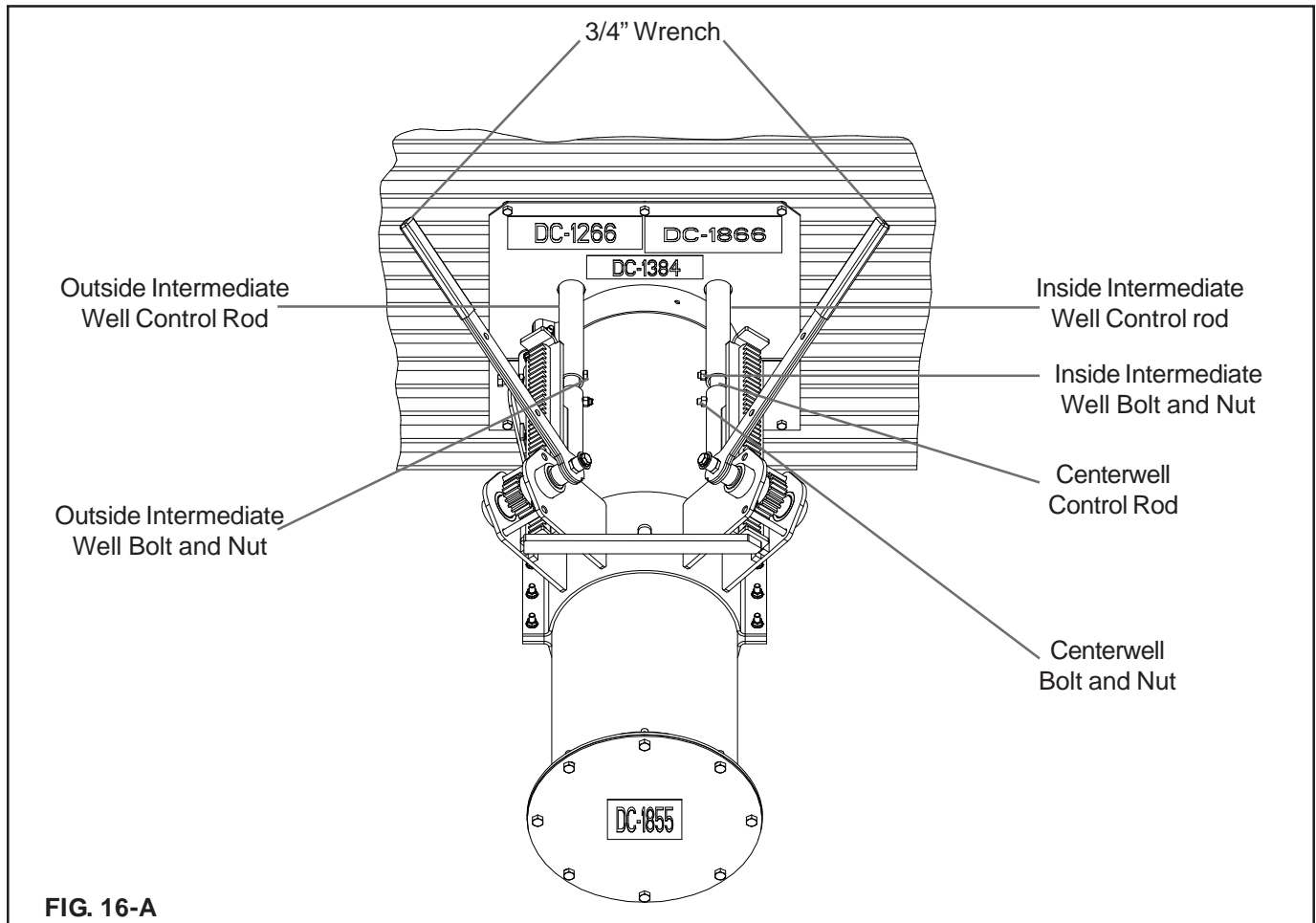

FIG. 16-A

16. NORMAL OPERATION (Cont.)

- C. Use the $\frac{3}{4}$ " Wrench on the Rack and Pinion and open the Centerwell Control Gate until the desired flow has been established. It should not be necessary to open the Gate more than 3" to 6". DO NOT open the Gate more than 3" to 6", as the flow of grain into the Centerwell will be at a higher rate than what the unload system can remove. This will cause the auger to plug or "jam."
- D. Always close the Centerwell Control Gate and allow the Unload Auger to clean out before stopping the Unload Auger.
- E. When the grain flow stops from the Centerwell, close the Centerwell Gate. Insert the Inside Intermediate Well Bolt and Nut through the Inside Intermediate Well Control Rod and the Centerwell Control Rod. The remaining grain should look like Figure 16-B.
- F. Gradually open the Centerwell and Inside Intermediate Wells until the desired flow has been established. You should not have to open the gate more than 2" to 4". DO NOT open the Gates more than 2" to 4", as the flow of grain into the Inside Intermediate Wells and occasional grain flow into the Centerwell will be at a higher rate than what the unload system can remove. This will cause the auger to plug or "jam."
- G. Always close the Well Gates and allow the Unload Auger to clean out before stopping the Unload Auger.

▲ WARNING

NEVER Unload the Bin from the Outside Intermediate Wells before unloading the grain from the Centerwell and Inside Intermediate Wells FIRST. This situation could result in structural damage to the Grain Bin.

- H. When the grain flow stops from the Centerwell and Inside Intermediate Wells, insert the Outside Intermediate Well Bolt and Nut through the Outside Intermediate Well Control Rod and the Outside Intermediate Well Adapter. The remaining grain should look like Figure 16-C.
- I. Gradually open the Outside Intermediate Wells until the desired flow has been established. You should not have to open the gate more than 2" to 4". DO NOT open the Gates more than 2" to 4", as the flow of grain into the Outside Intermediate Wells and occasional grain flow into the Centerwell and Inside Intermediate Wells will be at a higher rate than what the unload system can remove. This will cause the auger to plug or "jam."
- J. Always close all of the Well Gates and allow the Unload Auger to clean out before stopping the Unload Auger.

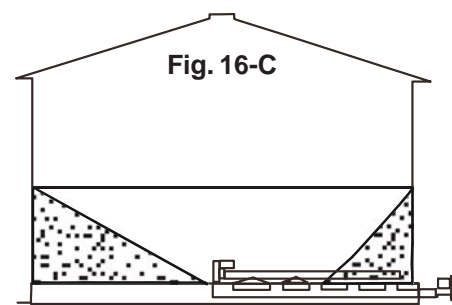
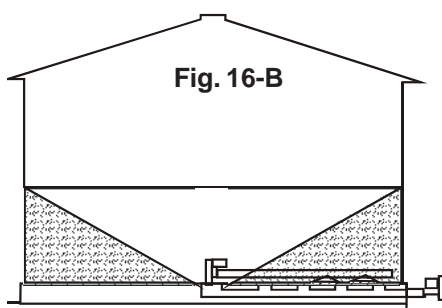

17. ENGAGING THE CLUTCH FOR THE BIN SWEEP

- A. All power should be disconnected and locked out before starting.
- B. Loosen the Clutch Control Pipe Position Lock Bolt. Pull on the Clutch Handle away from the Bin to engage the Clutch. Verify that the clutch is fully engaged, observing the distinguishing mark on the control rod, as done in Step 14E.
- C. Once the Clutch has been engaged, tighten the Clutch Control Pipe Position Lock Bolt to hold the Clutch Control rod in the engaged position.

⚠ CAUTION The Centerwell Gate must be **FULLY open** during the Bin Sweep operation.

- D. Restore power and start the Unload Auger motor. The Sweep Arm Augers will start, being powered by the Unload Auger. Each time the Auger is stopped, it may be necessary to adjust the Sweep Carrier Wheel Assembly up or down, so that the Arm is allowed to feed into the grain pile, but also not come into contact with the floor. Follow proper safety procedures before entering the bin to adjust the Carrier Wheel Assembly.

⚠ DANGER **DO NOT** enter a grain bin unless all power driven equipment has been shut down and locked out.

- D. The Sweep Arm Auger will clear most of the remaining grain in one pass. A second pass will clean out additional grain, before final clean out.

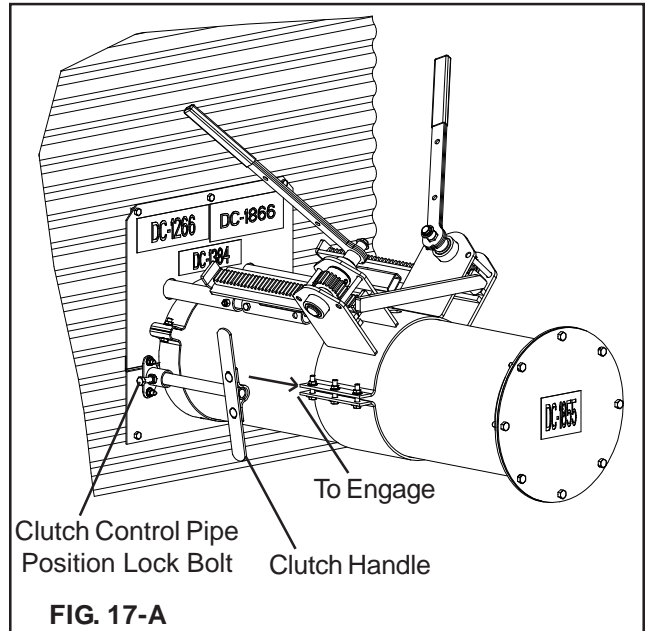

18. FINAL CLEAN-OUT



DO NOT enter a grain bin unless all power driven equipment has been shut down and locked out.

- A. After the Bin Sweep has made two passes removing most of the grain, it will be necessary to clean the floor.
- B. With all power disconnected and locked out, enter the grain bin. Sweep or scoop the remaining grain from the outer area of the floor, and move it to a circular pile towards the center of the bin. See Figure 18-A.

TOP VIEW OF BIN

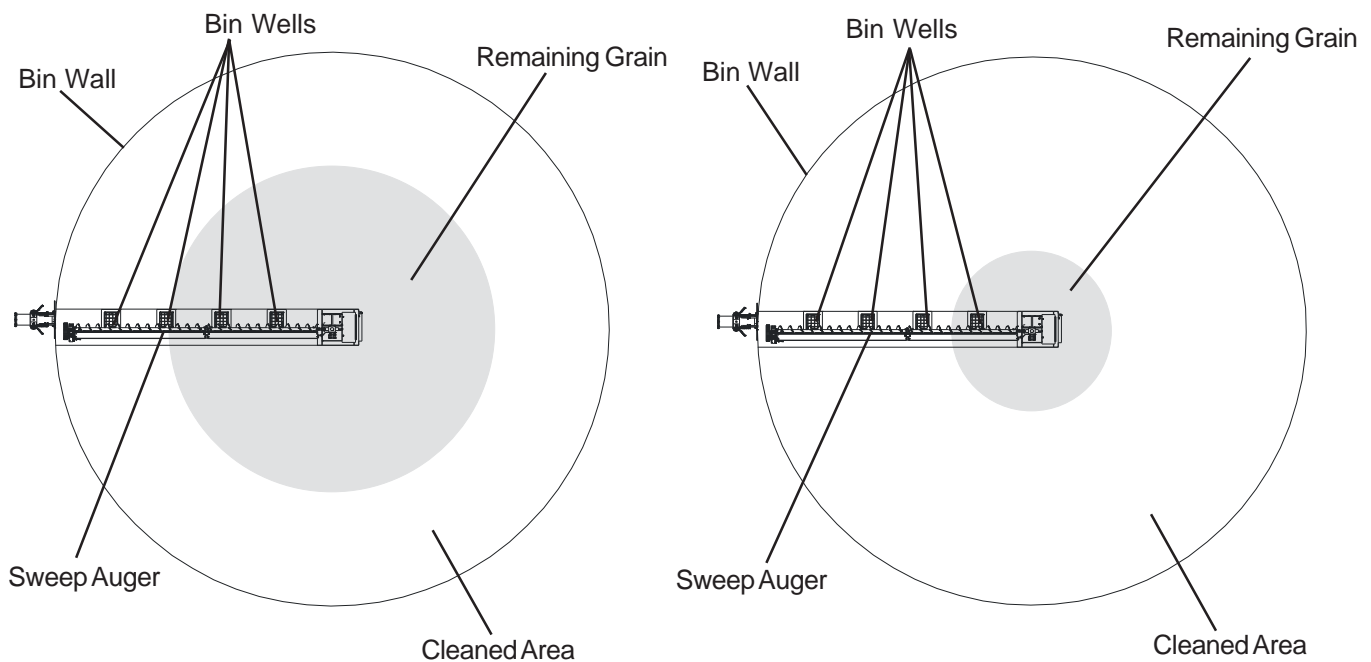

FIG. 18-A

FIG. 18-B

- C. Check the Sweep Carrier Wheel Assembly. If necessary, adjust the height so that the Sweep Arm Assembly is close to the floor, but will not contact the floor, Intermediate Well Top Flanges, or the floor screws.
- D. Exit the grain bin.
- E. Make sure everyone is outside of the bin and clear of the equipment.
- F. Start the Unload Auger with the Bin Sweep still engaged. Shortly, the swept pile will have been

18. FINAL CLEAN-OUT (Cont.)

removed by the Bin Sweep.

- F. Disconnect and lockout all power to the Unload Auger.
- G. Repeat Step B, moving the grain into a smaller circular pile, as shown in Figure 18-B.
- H. Repeat Step C.
- I. Exit the grain bin.
- J. Make sure everyone is outside of the bin and clear of the equipment.
- K. Start the Unload Auger with the Bin Sweep still engaged. Shortly, the swept pile will have been removed by the Bin Sweep.



Keep out of the bin while the Bin Sweep is in operation. The Bin Sweep travels rapidly around the bin. As the bin empties, the Bin Sweep travels around the bin faster.



Stay clear of the Unload Auger under the floor at the Bin Wells. The Unload Auger is exposed at these locations.

19. SHUTDOWN

A. Normal Shutdown

1. Before shutting down the unit, be sure the hoppers and augers are empty.
2. Disconnect and lockout the power source before leaving the work area.

B. Emergency Shutdown

1. Know how to shut down the auger in case of an emergency.
2. Do not restart the auger while it is under load.

⚠ DANGER

NEVER start the equipment under load. Doing so may cause damage. This type of damage is considered a misuse of the equipment. Any misuse of the equipment may void the warranty.

3. Close the bin well control gates.
4. Reconnect and unlock the power source.
5. Clear the auger gradually, until there is no grain and there are no obstructions.

C. Storage Preparation

1. Close all wells to the discharge auger.
2. Position the Direct Gear Drive Sweep along side the Intermediate Wells.

NOTE

Make sure the Clutch Control Rod is disengaged.

3. Be sure the Unload Tube is empty.
4. Shutdown the auger.
5. Make sure all fasteners are tight.

⚠ DANGER

DO NOT enter the grain bin unless all power driven equipment has been shutdown.

20. MAINTAIN THE AUGER

⚠ DANGER

Properly maintaining this equipment will help ensure it continues to work as designed. Failure to properly maintain this equipment may result in damage to the equipment and cause **SERIOUS INJURY** to the operator. Failure to properly maintain this equipment may also be a misuse of the equipment, and may void the warranty.

- A. The U-Joint must be lubricated with SAE Multipurpose Grease every 10 operational hours, or after each use.
- B. The Upper and Lower Gearboxes in the Centerwell should be half-full with oil. They must be checked and possibly filled with SAE 80W90 Gear Oil every 10 operational hours. Each Gearbox should be filled up to the fill plug, approximately making them half-full overall. It is recommended to replace the oil in the Gearboxes every season.
- C. Use caution when repairing or replacing equipment parts.
- D. Make sure ALL decals are legible and tightly attached to the equipment. If necessary, replace them **FREE OF CHARGE** by contacting the dealer, warehouse, or manufacturer.
- E. Mount controls for any electric motors at a safe distance from the machine and in a location accessible in case of an emergency.
- F. Make sure ALL electrical wiring is not damaged, and that it meets proper wiring codes.
- G. Make sure ALL components are in good working condition before use.

<i>Problem</i>	<i>Possible Cause</i>	<i>Solution</i>
1. The auger is vibrating.	A. The drive belt may be too tight, binding the head stub and flight. Damage can occur to the auger flighting, causing noise. Damage usually is caused from foreign material being run through the auger.	A1. Adjust the drive belt to the proper tightness. A2. It may be necessary to remove the flighting for inspection.
2. Capacity is too low.	A. There may not be enough grain reaching the auger.	A1. Make sure the intake has not bridged over, restricting flow. The flighting at the intake should be covered with grain for maximum capacity.
	B. The auger is moving too slowly.	B1. Check the auger speed. Low capacity will result from speeds slower than recommended.
3. The auger plugs.	A. The auger may be "jamming" because too much grain is reaching the auger.	A1. Decrease the amount of grain the auger is gathering.
	B. The motor may be too small or wired improperly.	B1. If the motor is a newer light weight aluminum type, the next larger size may be desirable.
	C. The grain may be wet.	C1. If wet grain or other hard-to-move material is being augered, use a larger size motor than recommended for normal use.
	D. The auger may be jammed with foreign material.	D1. Remove any foreign material in the auger.
	E. The discharge end may be plugged.	E1. Unplug any plugs at the discharge end of the auger.

<i>Problem</i>	<i>Possible Cause</i>	<i>Solution</i>
<p>4. The sweep flight and shield are no longer moving.</p>	<p>A. Too much drag.</p>	<p>A1. Check the clearance between the shield and the bin floor. Make sure there is room for the auger to move. Adjusting the shield may be necessary.</p>
	<p>B. Worn sweep wheel.</p>	<p>B1. The sweep wheel wears down over time. Replace the wheel.</p>
	<p>C. Unconditioned grain.</p>	<p>C1. Moisture and/or insects can cause the grain to harden or “cake-up”. Disconnect and lockout the power to the auger before going into the bin to correct this problem or to address any other problem.</p>

PARTS SECTION

CENTERWELL PARTS

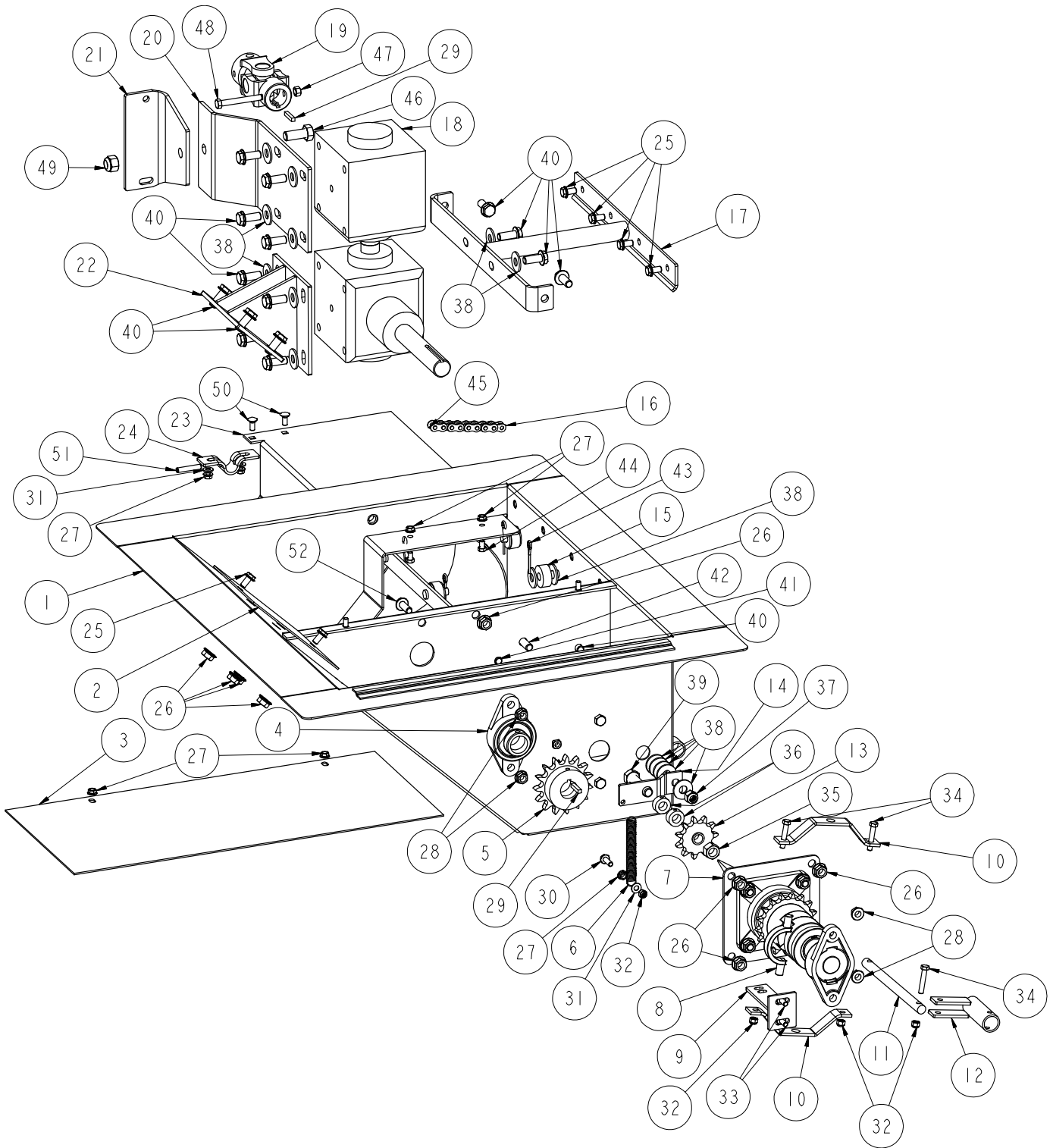

CENTERWELL PARTS

Centerwell Parts		
Ref #	Part #	Description
1	GK7552	Centerwell Weldment
2	GK7646	Centerwell Access Door
3	GK7575	Centerwell Cover Plate
4	GK1330	1-1/4" 2-Hole Flange Bearing w/ Lock Collar
5	GK2323	Sprocket #60 15T 1-1/4" Bore
6	GK1704	5" x 1/16" Pitch Return Spring
7	GK7583	Centerwell Shaft Assembly
8	GK7589	Brass Clutch Shifter Yoke
9	GK1693	Clutch Pivot Bracket
10	GK7592	Clutch Yoke Bracket
11	GK7637	Clutch Control Rod
12	GK1923	Clutch Control Arm
13	GK4941	Idler Sprocket #60 11T 5/8" Bore
14	GK1702	Idler Sprocket Bracket
15	GC03064	1/2" O.D. x 5/8" Polyurethane Roller
16	GK7664	Chain #60 42 Pitch
17	GK7573	Gearbox Mounting Bracket
18	GK7579	Centerwell Gearbox
19	GK7614	U-Joint 1-1/4" Bore & 1-1/2" Bore
20	GK7629	Gearbox Pivot Bracket
21	GK7630	Shield Pivot Bracket
22	GK7572	Wedge Gearbox Mount Weldment
23	GK7574	Centerwell Gate
24	GK1726	Centerwell Gate Clamp 1/2"
25	S-9067	3/8"-16 x 3/4" Flange Bolt Zinc Grade 5
26	S-8506	1/2"-13 Serrated Flange Nut Zinc
27	S-3611	5/16"-18 Serrated Flange Nut Zinc Grade 2
28	S-9073	7/16"-14 Serrated Flange Nut Zinc
29	S-8382	1/4" x 1-1/4" Square Key
30	S-7470	5/16"-18 x 1" Flange Bolt Zinc Grade 5
31	S-1937	5/16"-18 Flat Washer Zinc Grade 2
32	S-7382	5/16"-18 Nylock Nut Zinc Grade 5
33	S-6606	5/16"-18 x 3/4 Flange Bolt Zinc Grade 5
34	S-7149	5/16"-18 x 1-3/4" HHTB Grade 5
35	S-6494	5/8"-11 Deformed Nut Zinc Grade 5
36	S-4307	5/8" I.D. Lock Collar
37	S-8260	1/2"-13" Nylock Nut Zinc Grade 5
38	S-2121	1/2" Flat Washer Zinc
39	S-4108	5/8"-11 x 2-3/4" HHCS Zinc Grade 8
40	S-9062	1/2"-13 x 1-1/4" Flange Bolt Zinc Grade 5
41	S-7935	1/2"-13 x 1" HHCS Zinc Grade 5
42	S-7876	1/2"-13 x 1-3/4" HHCS Zinc Grade 5
43	S-7241	1/8" x 1-1/4" Cotter Pin Zinc Grade 2
44	S-8999	5/16"-18 x 1/2" HHCS Zinc Grade 5
45	S-8618	#60 Roller Chain Connecting Link
46	S-9009	5/8"-11 x 1-1/2" HHCS Zinc Grade 5
47	S-8251	3/8"-16 Stover Nut Zinc Grade C
48	S-7249	3/8"-16 x 3" HHCS Zinc Grade 5
49	S-8806	5/8"-11 Nylock Nut Zinc Grade 5
50	S-6076	5/16"-18 x 3/4" Carriage Bolt Zinc Grade 2
51	S-8397	5/16" x 1-3/4" Spring Pin
52	S-9072	7/16"-14 x 1-1/4" Flange Bolt Zinc Grade 5

CENTERWELL SHAFT ASSEMBLY PARTS

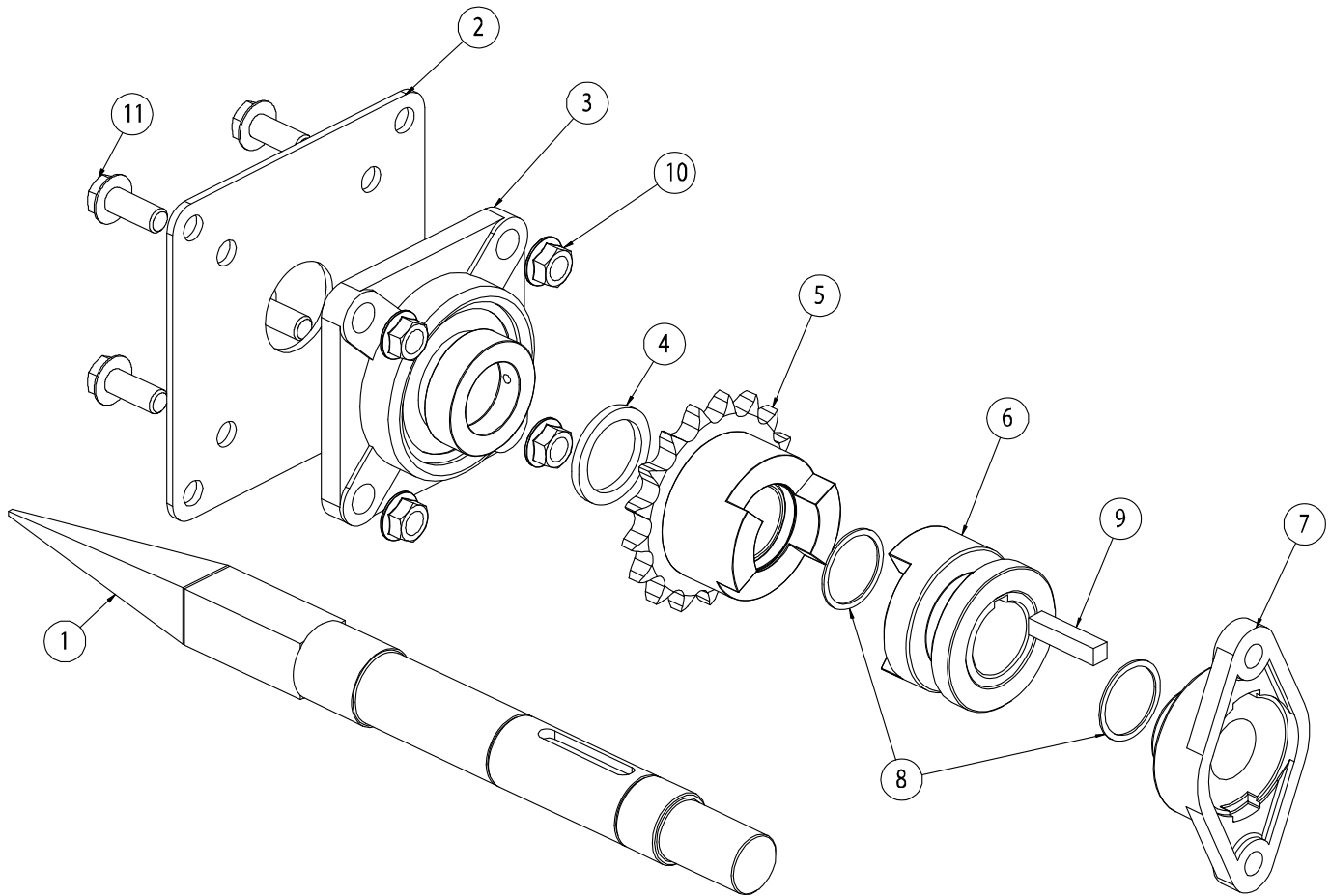

Centerwell Shaft Assembly		
Ref #	Part #	Description
1	GK7582	Centerwell Square Shaft
2	GK7581	Centerwell Assembly Bearing Plate
3	GK1343	1 1/2" 4-Hole Flange Bearing w/ Lock Collar
4	GK7830	Bushing: UHMW 1 1/2" Bore
5	GK7586	Clutch Jaw w/ Sprocket 1 1/2" Bore, #60 17T 2" Bore
6	GK7587	Clutch Yoke Retaining Jaw 1 1/2" Bore w/ 3/8" Keyway
7	GK1330	1 1/4" 2-Hole Flange Bearing w/ Lock Collar
8	GK7590	1 1/2" External Spiral Retaining Ring
9	S-9179	3/8" x 1 3/4" Square Key
10	S-8506	1/2"-13 Serrated Flange Nut Zinc
11	S-9062	1/2"-13 x 1 1/4" Flange Bolt Zinc Grade 5

UNLOAD TUBE CONNECTION PARTS

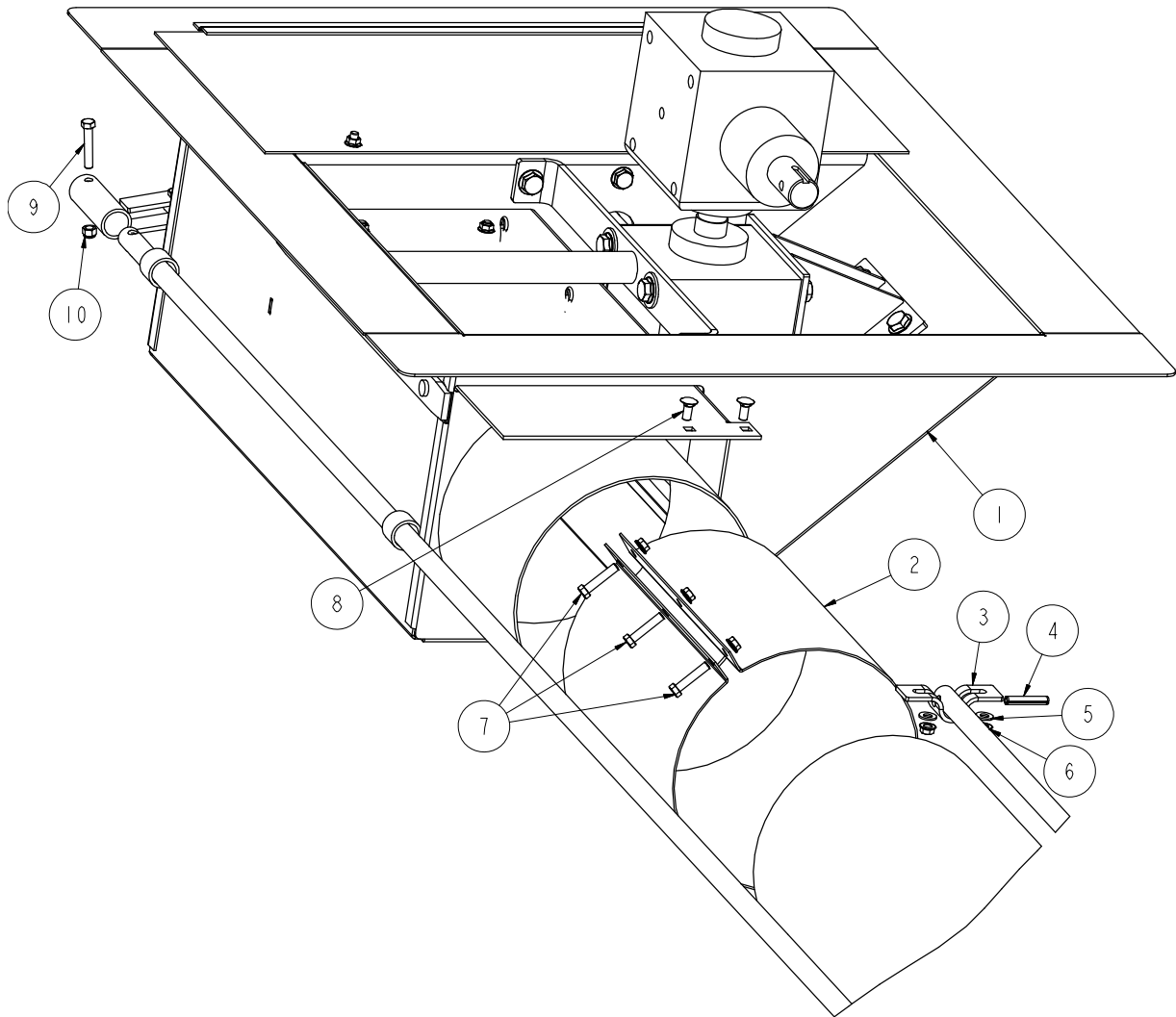

Unload Tube To Centerwell Connection Parts		
Ref #	Part #	Description
1	GK7635	Centerwell Assembly
2	GK1796	10" x 12" x 14 Gauge Connecting Band
3	GK1726	Control Gate Clamp 1/2"
4	S-8397	5/16" x 1 3/4" Spring Pin
5	S-1937	5/16" Flat Washer Zinc Grade 2
6	S-3611	5/16"-18 Serrated Flange Nut Zinc Grade 2
7	S-2741	5/16"-18 x 1 1/2" HHCS Zinc Grade 5
8	S-6076	5/16"-18 x 3/4" Carriage Bolt Zinc Grade 2
9	S-7149	5/16"-18 x 1 3/4" HHTB Grade 5
10	S-7382	5/16" Nylock Nut Zinc Grade 5

INTERMEDIATE INSIDE WELL PARTS

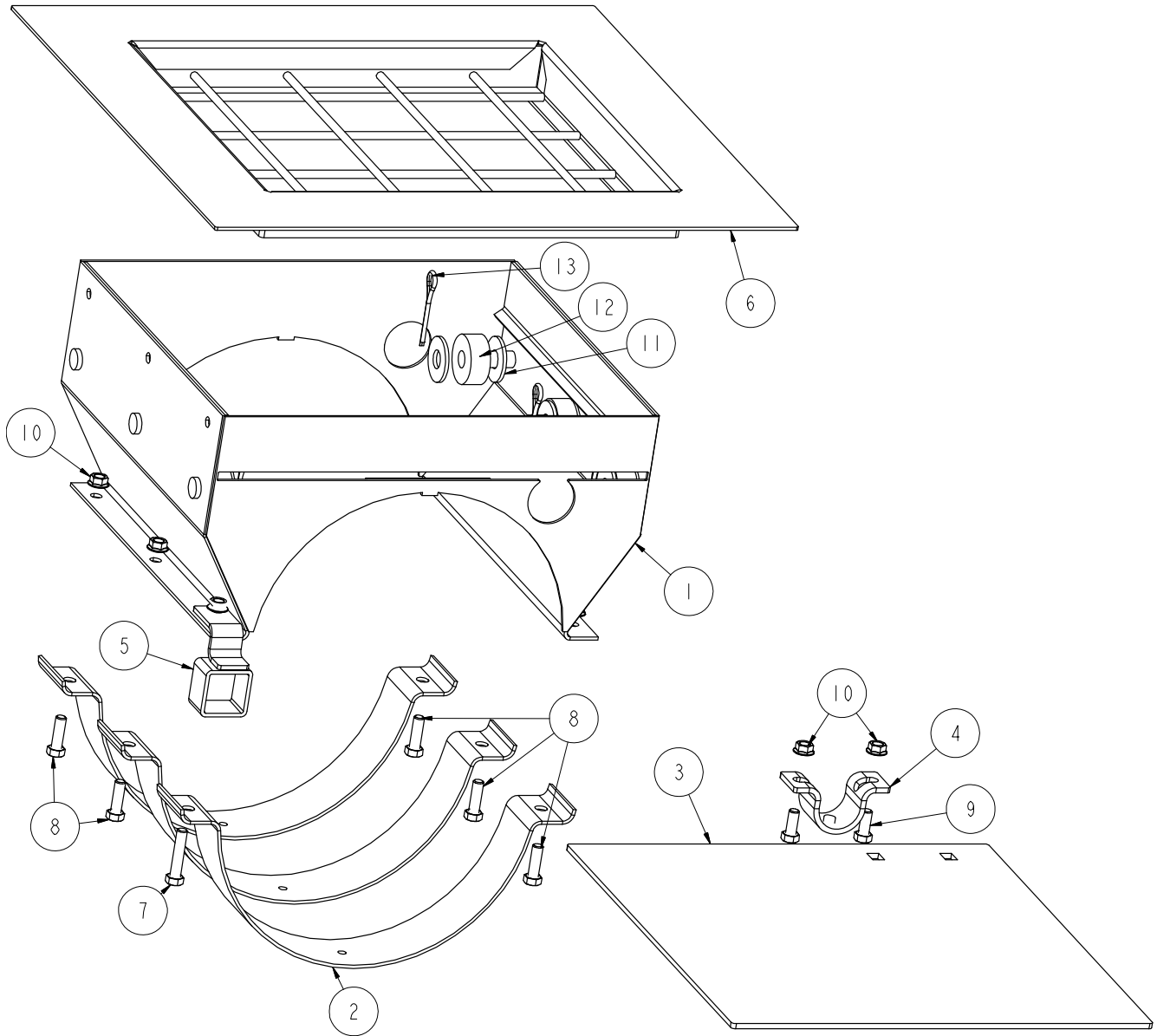

INTERMEDIATE OUTSIDE WELL PARTS

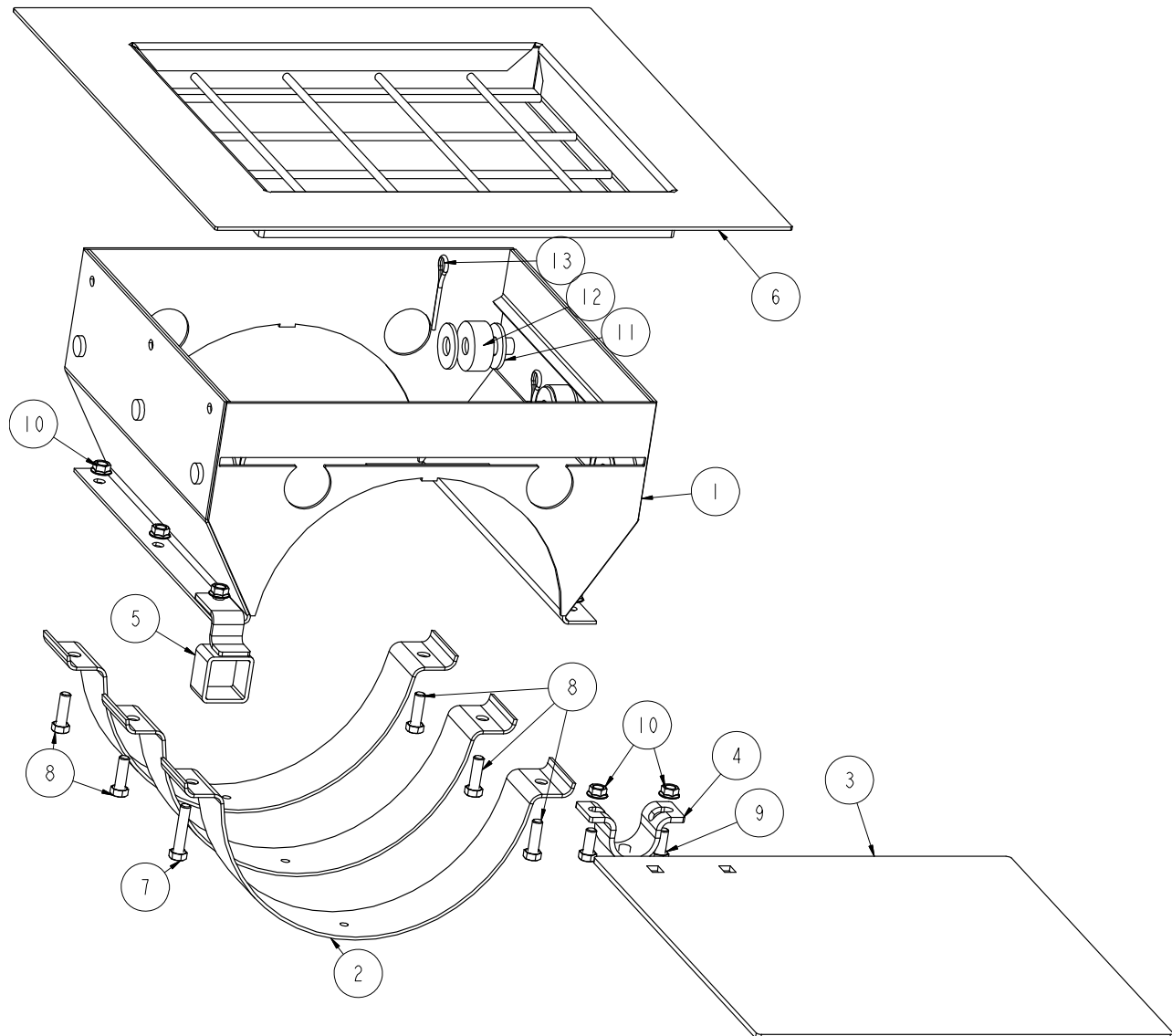

Intermediate Well Parts		
Ref #	Part #	Description
1	GC11554	Inside Intermediate Well
	GC11557	Outside Intermediate Well
2	GK1057	10" x 2" x 12 Gauge Half Band
3	GK7580	Intermediate Well Gate
4	GC09006	Control Pipe Clamp 1"
5	GK6714	Clutch Control Pipe Guide
6	GK7571	Intermediate Well Top Flange
7	S-2741	5/16"-18 x 1 1/2" HHCS Zinc Grade 5
8	S-1196	5/16"-18 x 1" HHCS Zinc Grade 5
9	S-4275	5/16"-18 x 3/4" HHTB Zinc Grade 5
10	S-3611	5/16"-18 Serrated Flange Nut Zinc Grade 2
11	S-2121	1/2" Flat Washer Zinc
12	GC03064	1/2" O.D. x 5/8" Polyurethane Roller
13	S-7241	1/8" x 1 1/4" Cotter Pin Zinc Grade 2

DOUBLE TUBE AND FLIGHT PARTS

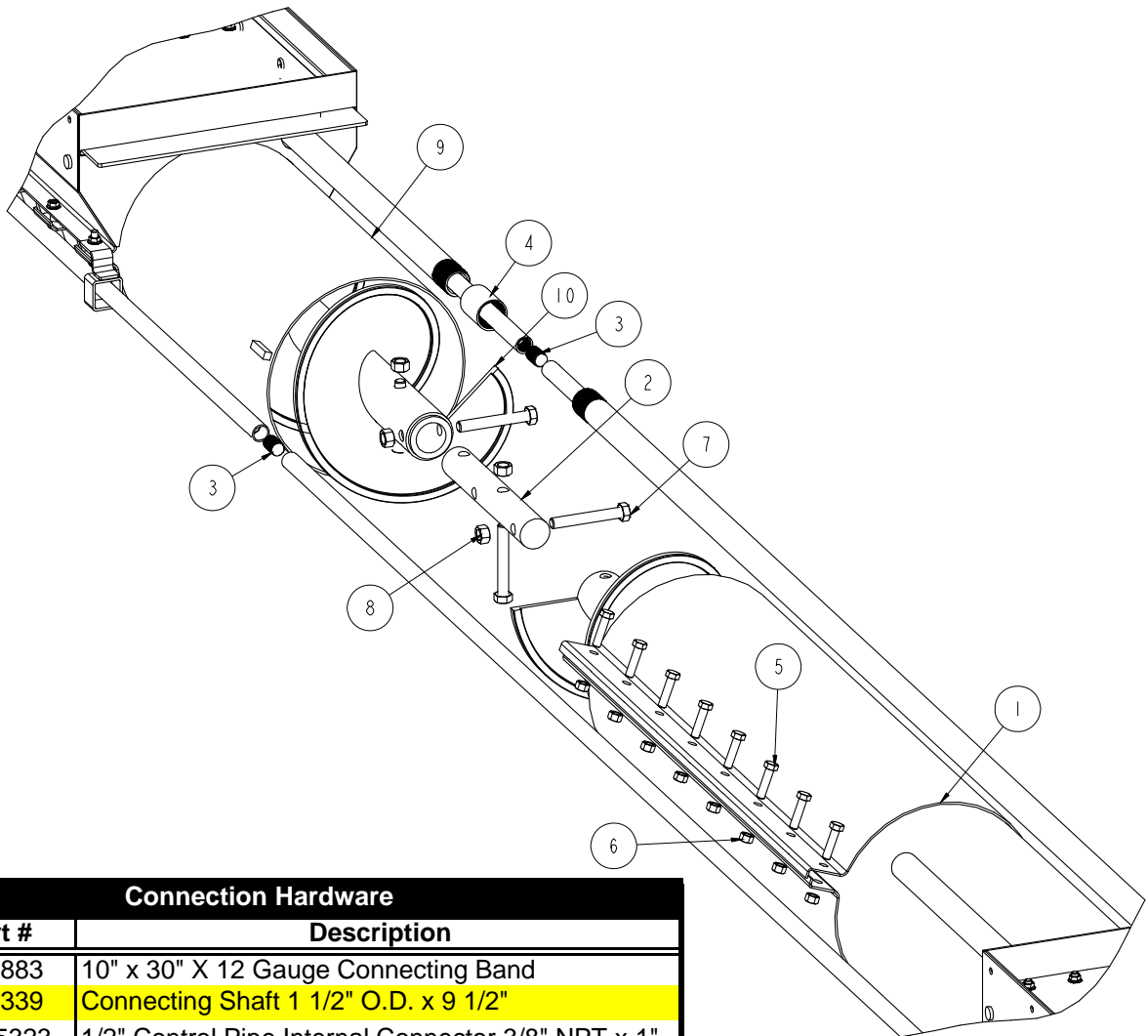

Connection Hardware		
Ref #	Part #	Description
1	GK1883	10" x 30" X 12 Gauge Connecting Band
2	GK1339	Connecting Shaft 1 1/2" O.D. x 9 1/2"
3	GC05323	1/2" Control Pipe Internal Connector 3/8" NPT x 1"
4	GT3-0462	1" Control Pipe External Coupler
5	S-7515	3/8"-16 x 1 1/2" Hex Bolt Stainless Steel
6	S-8251	3/8" Stover Nut Zinc Grade C
7	S-8314	1/2"-13 x 3 1/2" HHCS Zinc Grade 8
8	S-8315	1/2" Stover Nut Zinc Grade C
9	SEE TABLE	Unload Tube
10		Unload Flight

Tube & Flight												
Bin Dia.	Tube (9)				Flight (10)							
	Intake End		Discharge End		Intake End		Discharge End					
	Part #	Length	Part #	Length	Part #	Length	Part #	Length				
36'	GK7593	223.50"	N/A		GK7638	258.56"	N/A					
42'	GK7594	269.25"			GK7639	94.31"						
48'	GK7595	305.00"			GK7640	89.81"						
54'	GK7596	341.00"			GK7641	125.81"						
60'	GK7597	376.75"			GK7642	161.56"	GK5207	240.00"				
72'	GK7615	192.25"			GK7598	256.00"			GK7643	233.06"		
75'	GK7616	199.75"			GK7599	266.50"			GK7644	251.06"		
78'	GK7617	206.25"			GK7600	278.00"			GK7645	269.06"		

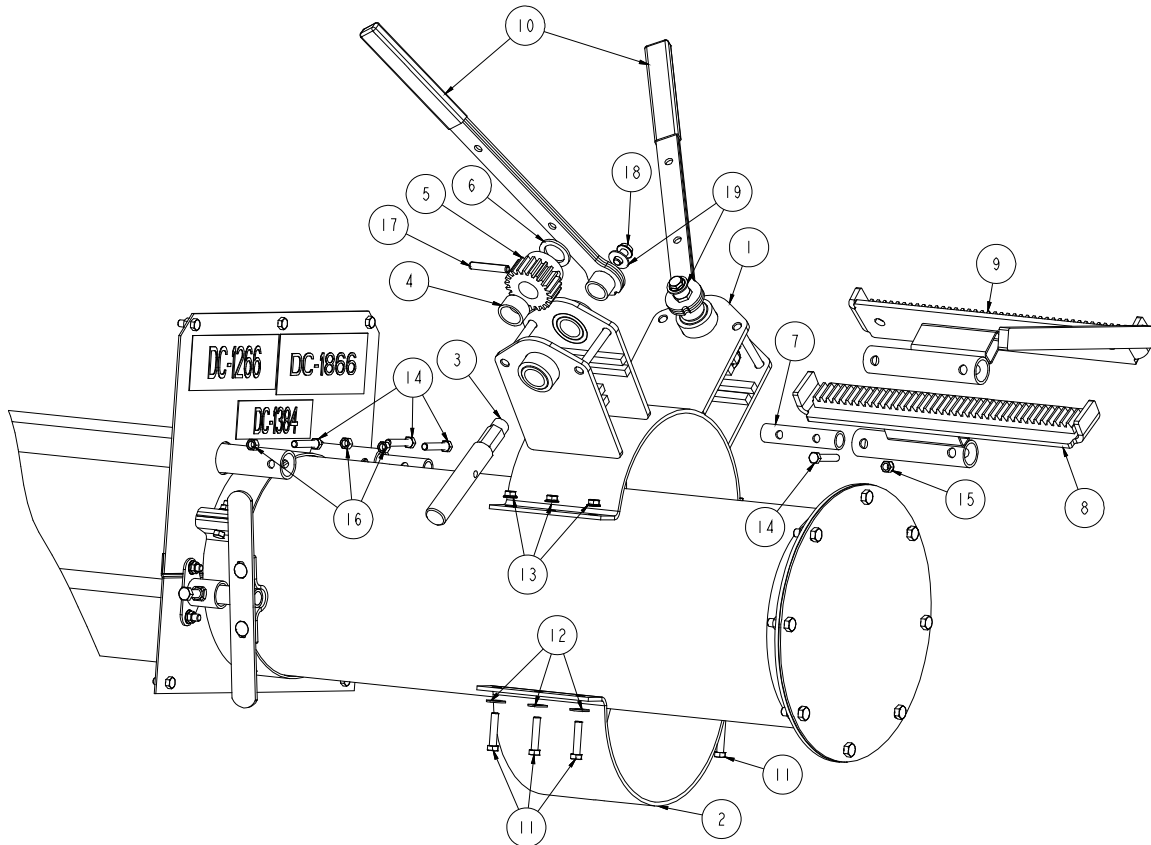

Well Gate Controls		
Ref #	Part #	Description
1	GK7568	42-78' Bin Rack & Pinion Housing Assembly
	GK6966	36' Bin Rack & Pinion Housing Assembly
2	GK5116	10" x 6" x 7 Gauge Half Band
3	GK6845	Rack & Pinion Crank Shaft
4	GK6841	Rack & Pinion Spacer Tube
5	GC09859	Spur Gear 10DP 1" Face 22T
6	GK4211	1" Flat Washer x 1 1/2" 10 Gauge Galvanized
7	GC11634	Outside Intermediate Well Rack & Pinion Adapter
8	GK7011	42'-78' Bin Outside Intermediate Rack Bar Assembly
9	GK7570	42'-78' Bin Inside Intermediate Rack Bar Assembly
	GK7011	36' Bin Rack Bar Assembly
10	GK7260	3/4" Wrench Assembly
11	S-2741	5/16"-18 x 1 1/2" HHCS Zinc Grade 5
12	S-845	5/16" Flat Washer Zinc Grade 2
13	S-3611	5/16"-18 Serrated Flange Nut Zinc Grade 2
14	S-7149	5/16"-18 x 1 3/4" HHTB Grade 5
15	S-7382	5/16" Nylock Nut Zinc Grade 5
16	S-396	5/16" Hex Nut Zinc Grade 2
17	S-4377	5/16" x 2" Grooved Roll Pin
18	S-9067	3/8"-16 x 3/4" Flange Bolt Zinc Grade 5
19	S-248	3/8" Flat Washer Zinc Grade 2

BIN FLANGE PARTS AND CONTROL PIPES

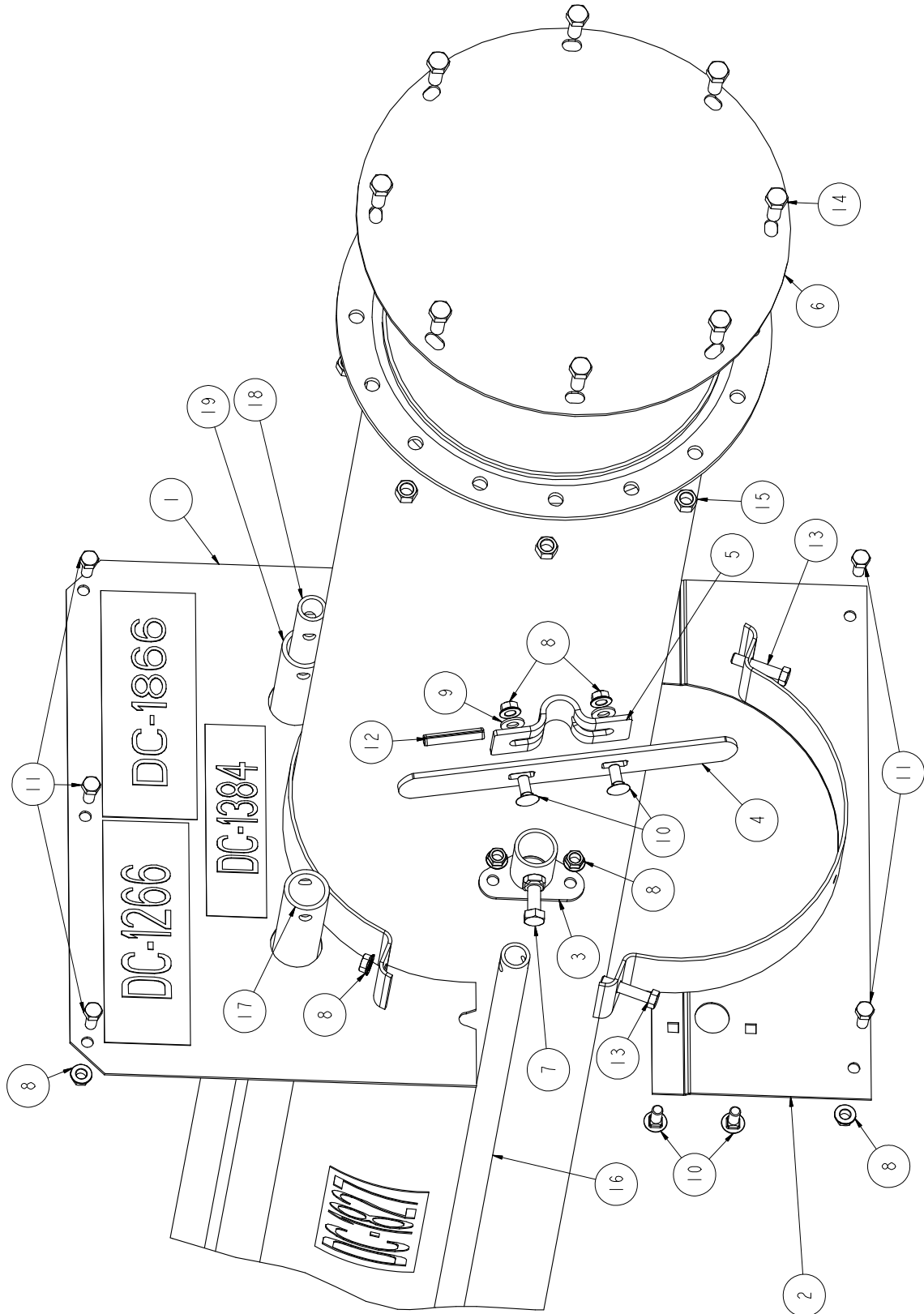

Control Pipes													
Bin Dia.	Outside Int. Well (17)			Inside Intermediate Well (19)			Centerwell (18)			Clutch (16)			
	Part #	Length	Intake End	Discharge End	Part #	Length	Intake End	Discharge End	Part #	Length	Intake End	Discharge End	
36'	N/A		GC11621	191.75"	N/A		GC11624	212.25"	N/A	GC11681	248.50"	N/A	
42'	GK11619	131.25"	GC11620	85.25"	GC11614	146.00"	GC11625	248.00"				GC11682	33.25"
48'	GC11617	143.25"	GC11618	113.75"			GC11626	35.25"				GC11683	69.00"
54'	GC11615	159.50"	GC11616	193.50"	GC11613	95.00"	GC11627	71.25"				GC11684	105.00"
60'	GC11612	149.75"	GC11611	234.00"			GC11628	107.00"		GK1776	252.00"	GC11685	104.75"
72'	GC11610	214.25"	GC11609	158.50"			GC11629	178.50"				GC11686	212.25"
75'	GC11605	222.25"	GC11604	166.25"	GC11606	248.00"	GC11630	196.50"				GC11687	230.25"
78'	GC11608	230.25"	GC11607	181.75"			GC11631	214.50"				GC11688	248.25"

Bin Flange Components		
Ref #	Part #	Description
1	GK7577	42"-78" Bin Top Bin Flange Weldment
	GC10560	36" Bin Top Bin Flange Weldment
2	GC10558	10" Bottom Bin Flange Weldment
3	GK1619	Clutch Control Pipe Position Lock
4	GC01192	Clutch Control Pipe Handle
5	GK1726	Control Gate Clamp 1/2"
6	GK2184	10" 8-Hole End Cap
7	S-2071	3/8"-16 x 1 1/4" HHCS Zinc Grade 5
8	S-3611	5/16"-18 Serrated Flange Nut Zinc Grade 2
9	S-1937	5/16" Flat Washer Zinc Grade 2
10	S-6076	5/16"-18 x 3/4" Carriage Bolt Zinc Grade 2
11	S-275	5/16"-18 x 3/4" Grade 5
12	S-8397	5/16" x 1 3/4" Spring Pin
13	S-2741	5/16"-18 x 1 1/2" HHCS Zinc Grade 5
14	S-7469	1/2"-13 x 3 1/4" HHCS Zinc Grade 5
15	S-456	3/8" Hex Nut Zinc Grade 5
16		Clutch Control Rod
17	SEE TABLE	Outside Intermediate Control Rod
18		Centerwell Control Rod
19		Inside Intermediate Control Rod

ASSEMBLED SWEEP ARM PARTS

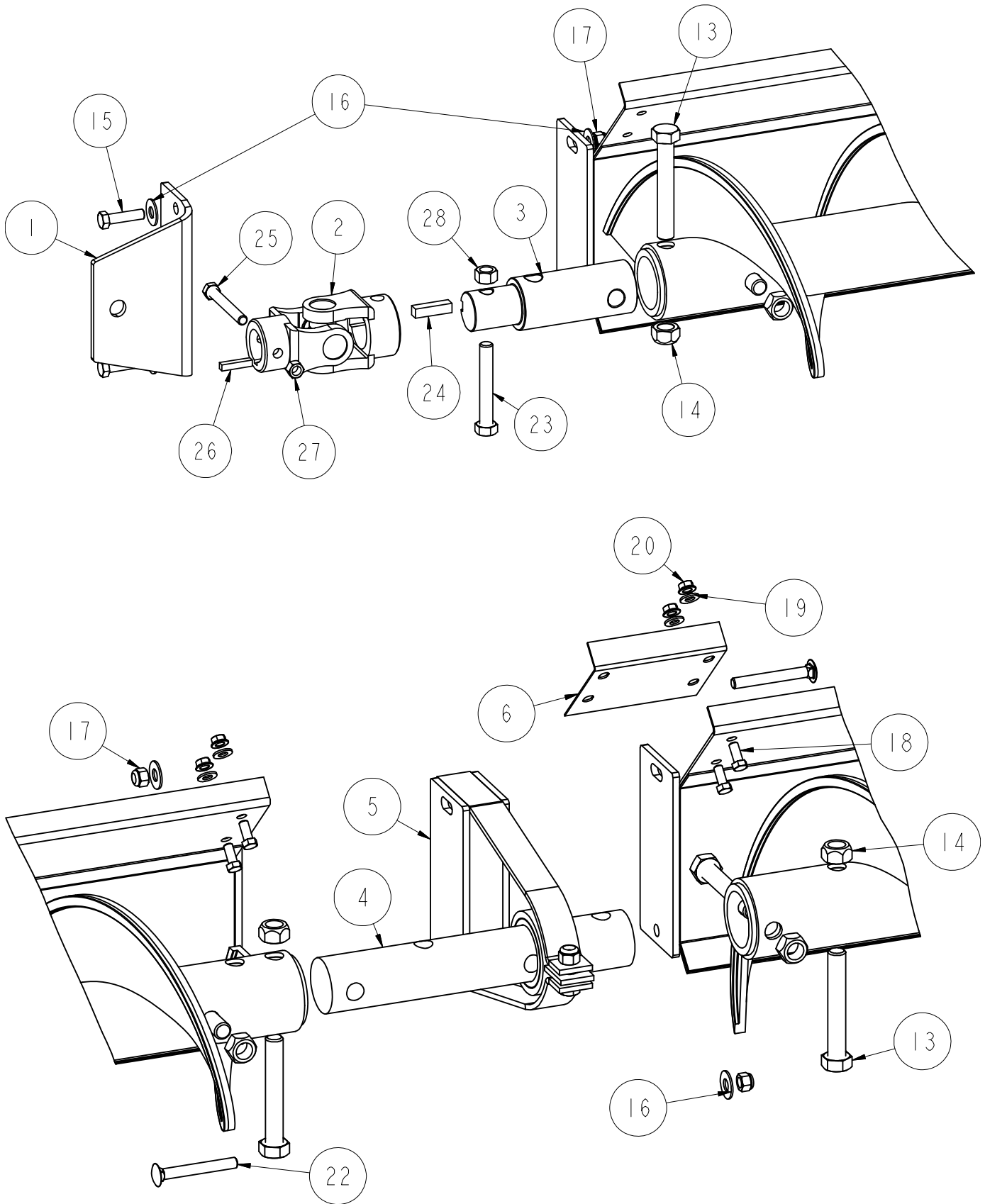

ASSEMBLED SWEEP ARM PARTS

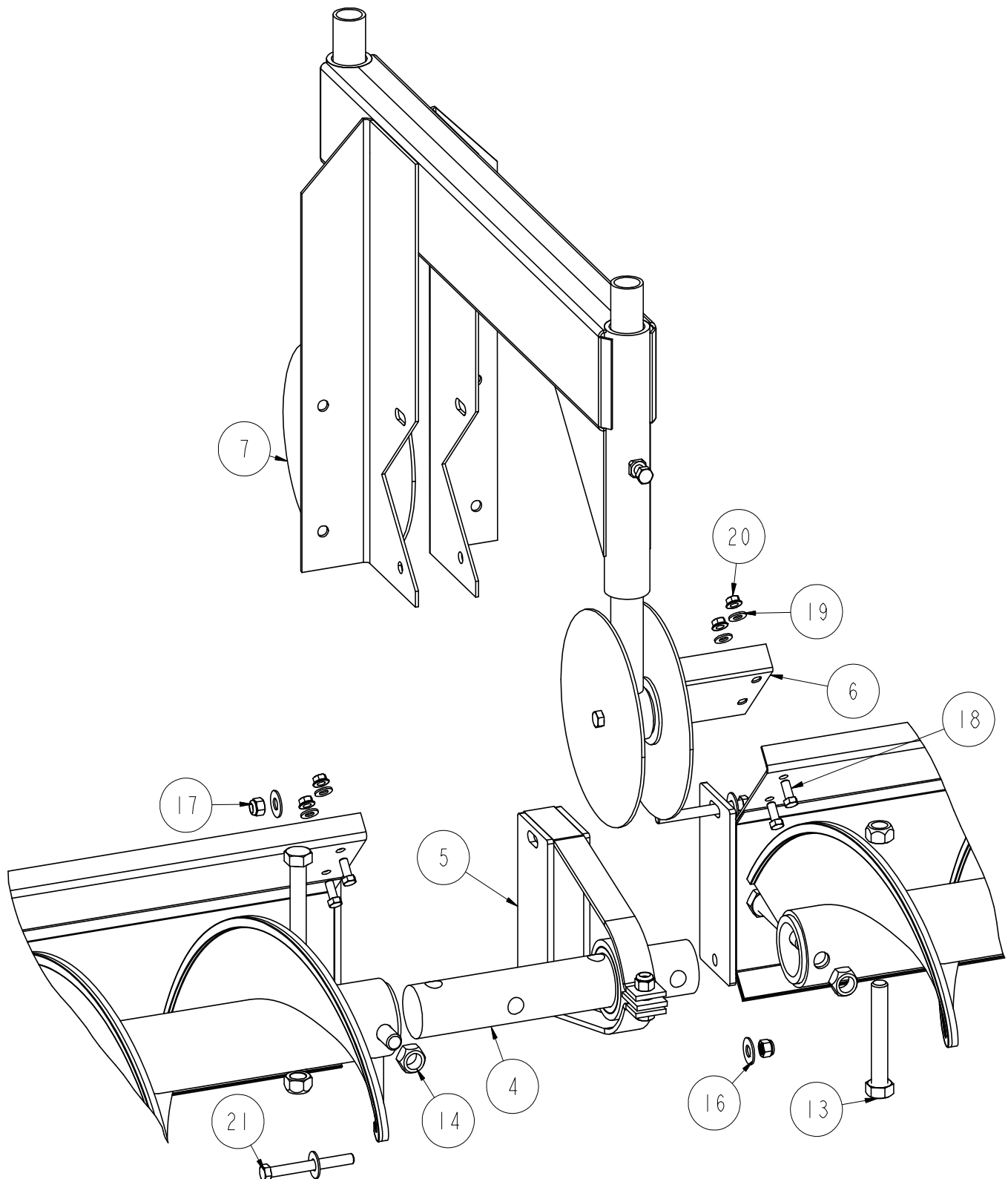

ASSEMBLED SWEEP ARM PARTS

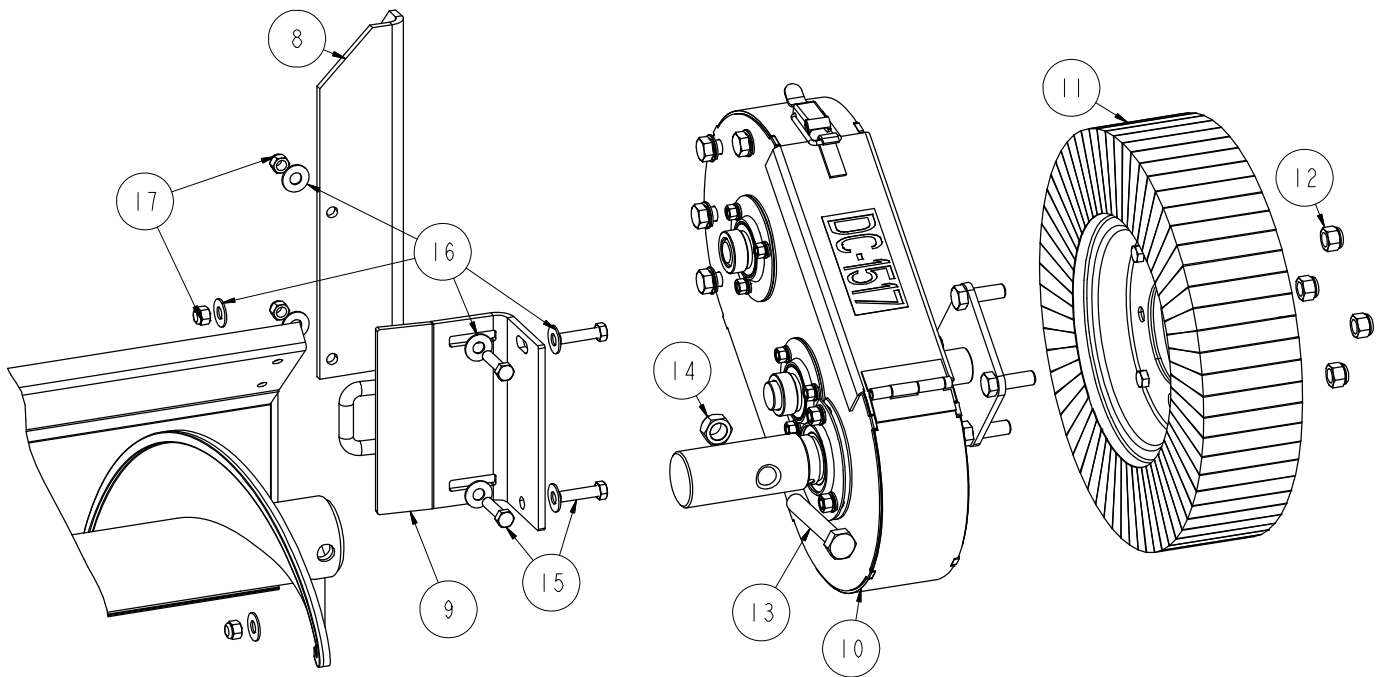

Assembled Sweep Arm Components			Flight & Shield Bundle Components		
Ref #	Part #	Description	Bundle #	Part #	Description
1	GK7630	Shield Pivot Bracket	GK5376	Flight & Shield Bundle 5' - 3-1/2"	
2	GK7614	U-Joint 1-1/4" Bore & 1-1/2" Bore		GK2280	9" x 5' - 3-1/2" x 1/4" Flight Weldment
3	GK7602	U-Joint Flight Shaft		GK2279	5' - 3-1/2" Shield Assembly
4	GK2222	Connecting Shaft 2" O.D. x 11-1/2"	GK5378	Flight & Shield Bundle 6' - 9-1/2"	
5	GK2047	Bearing Stand Assembly		GK2294	9" x 6' - 9-1/2" x 1/4" Flight Weldment
6	GK5615	Shield Splice Plate		GK2293	6' - 9-1/2" Shield Assembly
7	GK5162	Carrier Wheel Assembly	GK5379	Flight & Shield Bundle 8' - 3-1/2"	
8	GK2346	Sweep Wheel Housing Bracket		GK2299	9" x 8' - 3-1/2" x 1/4" Flight Weldment
9	GK2347	Mounting Bracket With Anchor Loop		GK2298	8' - 3-1/2" Shield Assembly
10	GK2345	Enclosed Chain Drive For Sweep Wheel	GK5380	Flight & Shield Bundle 8' - 10"	
11	GK2344	Segmented Rubber Wheel		GK2284	9" x 8' - 10" x 1/4" Flight Weldment
12	S-8260	1/2"-13 Nylock Nut Zinc Grade 5		GK2283	8' - 10" Shield Assembly
13	S-7893	5/8"-11 x 4" HHCS Zinc Grade 8	GK5381	Flight & Shield Bundle 9' - 3-1/2"	
14	S-8606	5/8"-11 Stover Nut Zinc Grade C		GK2296	9" x 9' - 3-1/2" x 1/4" Flight Weldment
15	S-2086	3/8"-16 x 1-1/2" HHCS Zinc Grade 8		GK2295	9' - 3-1/2" Shield Assembly
16	S-248	3/8" Flat Washer Zinc Grade 2	GK5382	Flight & Shield Bundle 9' - 9-3/4"	
17	S-7383	3/8"-16 Nylock Nut Zinc Grade 5		GK2289	9" x 9' - 9-3/4" x 1/4" Flight Weldment
18	S-4275	5/16"-18 x 3/4" HHTB Zinc Grade 5		GK2288	9' - 9-3/4" Shield Assembly
19	S-1937	5/16" Flat Washer Zinc Grade 2			
20	S-3611	5/16"-18 Flange Whizz Nut Zinc Grade 2			
21	S-8676	3/8"-16 x 3-1/2" HHCS Zinc Grade 5			
22	S-8055	3/8"-16 x 3" Carriage Bolt Zinc Grade 5			
23	S-7946	1/2"-13 x 3-1/4" HHCS Zinc Grade 5			
24	S-4516	3/8" x 1-1/2" Square Key			
25	S-7249	3/8"-16 x 3" HHCS Zinc Grade 5			
26	S-8382	1/4" x 1-1/4" Square Key			
27	S-8251	3/8"-16 Stover Nut Zinc Grade C			
28	S-8315	1/2"-13 Stover Nut Zinc Grade C			

SWEEP CARRIER PARTS

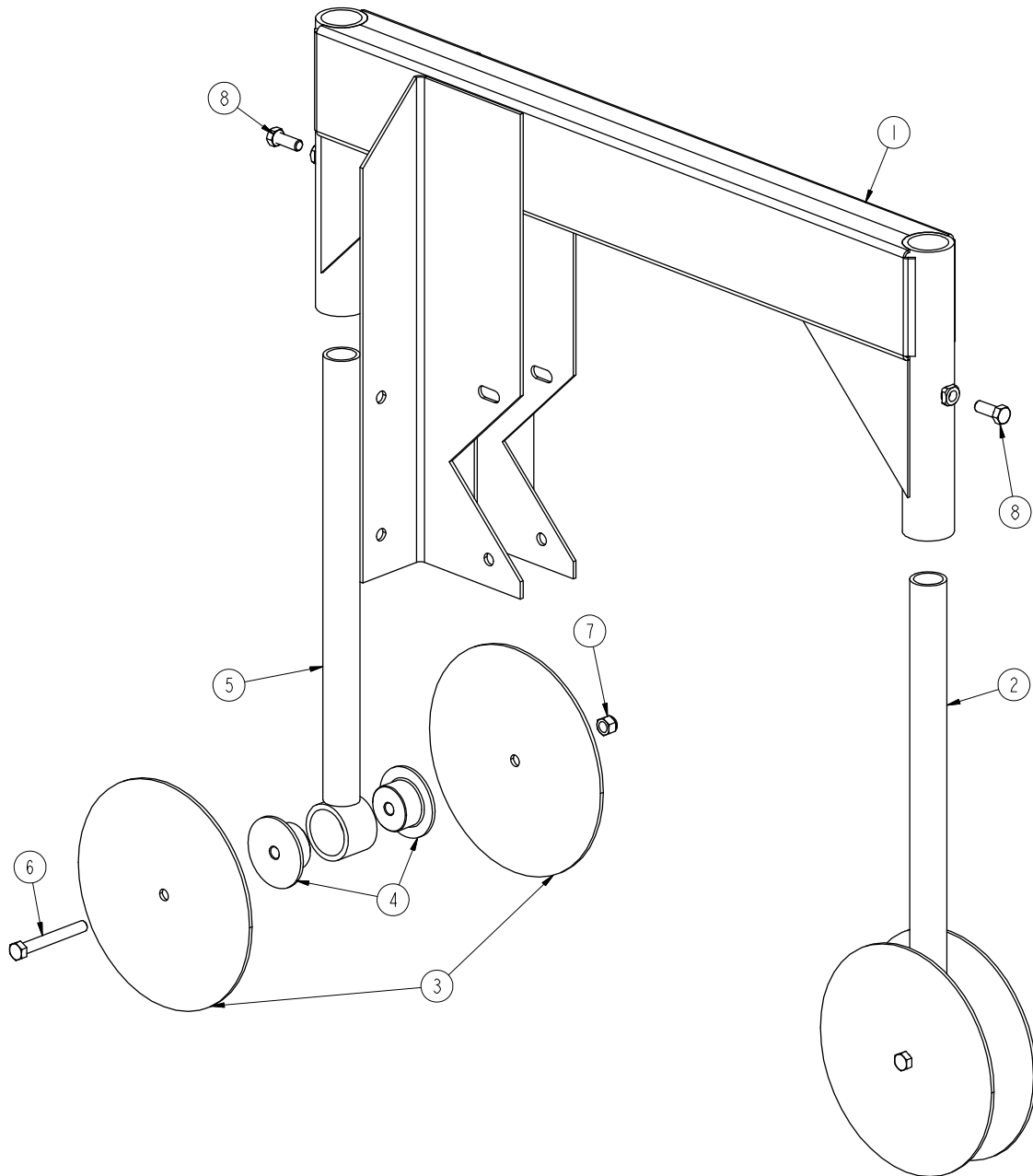

Sweep Carrier Assembly		
Ref #	Part #	Description
1	GK5163	Sweep Carrier Body
2	GK5164	Sweep Carrier Leg Assembly
3	GK2085	Sweep Wheel Disc
4	GC09726	Sweep Carrier Wheel Bushing
5	GK5165	Sweep Carrier Wheel Leg
6	S-7249	3/8"-16 x 3" HHCS Zinc Grade 5
7	S-7383	3/8" Nylock Nut Zinc Grade 5
8	S-7469	3/8"-16 x 1" HHCS Zinc Grade 5

ENCLOSED CHAIN DRIVE PARTS

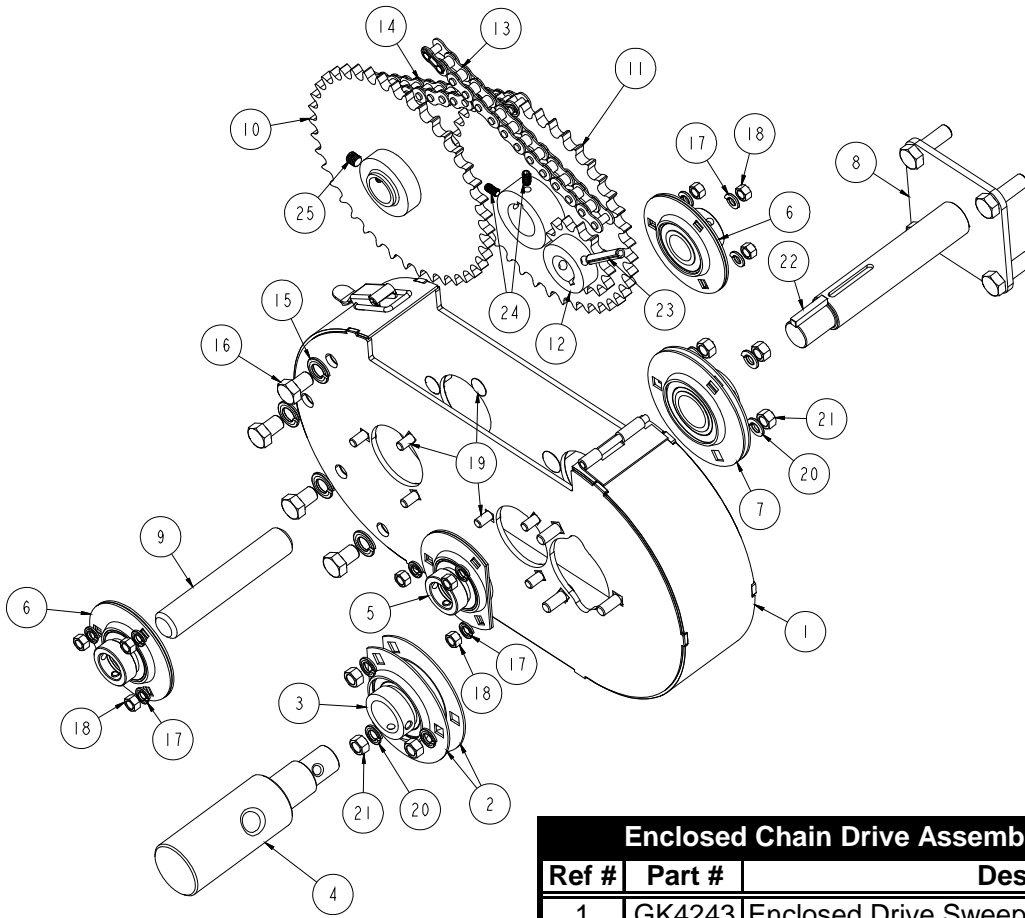

Enclosed Chain Drive Assembly for Sweep Wheel

Ref #	Part #	Description
1	GK4243	Enclosed Drive Sweep Wheel Housing
2	GK2359	1 1/4" 3-Hole Flangette, Cutback 51/64"
3	GK1008	1 1/4" Bearing w/ Lock Collar
4	GK2352	2" to 1" Input Shaft
5	GK2360	1" 3-Hole Flangette, Cutback 21/32"
6	GK1583	1" 3-Hole Flangette Bearing w/ Lock Collar
7	GK7221	1 1/4" 3-Hole Flangette Bearing w/ Lock Collar
8	GK2351	Wheel Shaft Weldment
9	GK2353	1" x 5 5/8" Idler Shaft
10	GK2354	Double Sprocket Assembly #50 40T 13T
11	GK2356	Sprocket #50 40T 1 1/4" Bore
12	GK4249	Sprocket #50 13T 1" Bore
13	GK2357	#50 x 54P Chain
14	GK2358	#50 x 46P Chain
15	S-236	1/2" Lock Washer Zinc
16	S-7932	1/2"-13 x 3/4" HHCS Zinc Grade 5
17	S-1147	5/16" Lock Washer Zinc
18	S-396	5/16" Hex Nut Zinc Grade 2
19	S-6076	5/16"-18 x 3/4" Carriage Bolt Zinc Grade 2
20	S-1054	3/8" Lock Washer Zinc
21	S-456	3/8" Hex Nut Zinc Grade 5
22	S-9169	1/4" x 1 1/2" Square Key
23	S-4377	5/16" x 2" Grooved Roll Pin
24	S-2742	1/4"-20 x 1/2" Set Screw
25	S-7256	3/8"-16 x 3/8" Set Screw

THE GSI GROUP, INC. WARRANTY

THE GSI GROUP, INC. ("GSI") WARRANTS ALL PRODUCTS WHICH IT MANUFACTURES TO BE FREE OF DEFECTS IN MATERIAL AND WORKMANSHIP UNDER NORMAL USAGE AND CONDITIONS FOR A PERIOD OF 12 MONTHS AFTER RETAIL SALE TO THE ORIGINAL END USER. THE PURCHASER'S SOLE REMEDY AND GSI'S ONLY OBLIGATION SHALL BE TO REPAIR OR REPLACE, AT GSI'S OPTION AND EXPENSE, PRODUCTS THAT, IN GSI'S SOLE JUDGMENT, CONTAIN A MATERIAL DEFECT DUE TO MATERIALS OR WORKMANSHIP. ALL DELIVERY AND SHIPMENT CHARGES TO AND FROM GSI'S FACTORY WILL BE PURCHASER'S RESPONSIBILITY. EXPENSES INCURRED BY OR ON BEHALF OF THE PURCHASER WITHOUT PRIOR WRITTEN AUTHORIZATION FROM AN AUTHORIZED EMPLOYEE OF GSI SHALL BE THE SOLE RESPONSIBILITY OF THE PURCHASER.

EXCEPT FOR THE LIMITED WARRANTY EXPRESSED ABOVE, GSI MAKES NO FURTHER WARRANTY OF ANY KIND, EXPRESS OR IMPLIED, INCLUDING, WITHOUT LIMITATION, WARRANTIES OF MERCHANTABILITY OR FITNESS FOR A PARTICULAR PURPOSE OR USE IN CONNECTION WITH (I) PRODUCT MANUFACTURED OR SOLD BY GSI OR (ii) ANY ADVICE, INSTRUCTION, RECOMMENDATION OR SUGGESTION PROVIDED BY AN AGENT, REPRESENTATIVE OR EMPLOYEE OF GSI REGARDING OR RELATED TO THE CONFIGURATION, INSTALLATION, LAYOUT, SUITABILITY FOR A PARTICULAR PURPOSE, OR DESIGN OF SUCH PRODUCTS.

GSI SHALL NOT BE LIABLE FOR ANY DIRECT, INDIRECT, INCIDENTAL OR CONSEQUENTIAL DAMAGES, INCLUDING, WITHOUT LIMITATION, LOSS OF ANTICIPATED PROFITS OR BENEFITS. PURCHASER'S SOLE AND EXCLUSIVE REMEDY IS AS SET FORTH IN THE LIMITED WARRANTY EXPRESSED ABOVE, WHICH SHALL NOT EXCEED THE AMOUNT PAID FOR THE PRODUCT PURCHASED. THIS WARRANTY IS NOT TRANSFERABLE AND APPLIES ONLY TO THE ORIGINAL PURCHASER. GSI SHALL HAVE NO OBLIGATION OR RESPONSIBILITY FOR ANY REPRESENTATIONS OR WARRANTIES MADE BY OR ON BEHALF OF ANY DEALER, AGENT OR DISTRIBUTOR OF GSI.

GSI ASSUMES NO RESPONSIBILITY FOR CLAIMS RESULTING FROM ERECTION DEFECTS OR UNAUTHORIZED MODIFICATIONS TO PRODUCTS WHICH IT MANUFACTURED. MODIFICATIONS TO PRODUCTS NOT SPECIFICALLY DELINEATED IN THE MANUAL ACCOMPANYING THE EQUIPMENT AT INITIAL SALE WILL NULLIFY THE PRODUCT WARRANTY THAT MIGHT HAVE BEEN OTHERWISE AVAILABLE.

THE FOREGOING WARRANTY SHALL NOT EXTEND TO PRODUCTS OR PARTS WHICH HAVE BEEN DAMAGED BY NEGLIGENT USE, MISUSE, ALTERATION OR ACCIDENT. THIS WARRANTY EXTENDS SOLELY TO ONLY PRODUCTS MANUFACTURED BY GSI. THIS WARRANTY IS EXCLUSIVE AND IN LIEU OF ALL OTHER WARRANTIES EXPRESS OR IMPLIED. GSI RESERVES THE RIGHT TO MAKE DESIGN OR SPECIFICATION CHANGES AT ANY TIME.

PRIOR TO INSTALLATION, PURCHASER HAS THE RESPONSIBILITY TO COMPLY WITH ALL FEDERAL, STATE AND LOCAL CODES WHICH MAY APPLY TO THE LOCATION AND INSTALLATION OF PRODUCTS MANUFACTURED OR SOLD BY GSI.

This Equipment shall be installed in accordance with the current installation codes and applicable regulations which should be carefully followed in all cases. Authorities having jurisdiction should be consulted before installation occurs.

G S I G R O U P



The GSI Group, Inc.
1004 E. Illinois St.
Assumption, IL 62510-0020
Phone: 217-226-4421
Fax: 217-226-4420
e-mail: gsisales@grainsystems.com
internet: <http://www.grainsystems.com>